



CHEMICAL CONTROLLER

MODEL CM 55

INSTALLATION AND OPERATING MANUAL

Australian and New Zealand distributors :

20 Abrams Street, Balcatta, WA 6021

Sales/Service: 1300 550 010

Fax: 1300 895 231

Swimline Products : N.S.W. (02)9971 2306 fax:(02)9971 7592

Flowcontrol Pty Ltd: S.A. (08)8346 9100 fax: (08) 8358 6015

Pioneer Pools: SOUTH ISLAND N.Z. 03 348 4592 Fax 03 348 4593

W.A. Coleman Ltd WELLINGTON N.Z..06 376 8099

P.Coleman .AUCKLAND .N.Z. 64 737 78486

FOR MORE INFORMATION ON OUR DISTRUBITORS VISIT OUR
WEB SITE ON www.poolcontrols.com.au.
OR EMAIL US AT sales@poolcontrols.com.au

**DO NOT DISCARD THIS MANUAL
WHEN THE INSTALLATION IS COMPLETE
AS IT PROVIDES IMPORTANT INFORMATION
FOR OPERATING THE UNIT.**

NOTES**CONTENTS**

	PAGE
Important Safety Instructions	3
Message to the New Owner	5
PREPARATION	
Items Supplied	7
Tools Required	8
Other Items Required	9
Options Available	9
INSTALLATION	
Location	11
Chemigem Installation	11
Tapping Band Installation	11
Drill & Tap Installation	13
Multi-electrode Installation	13
Chemical Drums Installation	13
Fitting Chemigem to a Heated Pool	14
Fitting Chemigem Below Pool Water Surface Level	14
Venturi System	14
Neatening Up	15
Delivery Systems Available	15
Solenoid Valves	15
Installation Diagrams	
Chemigem Installation	16
Fitting Tapping Band and Multi-electrode	17
Drill and Tap Multi-electrode and Injector Installation	18
Drill & Tap Installation for Large Diameter Pipe	19
Fitting Chemigem Below Pool Surface Level	20
Fitting Chemigem to a Heated Pool	21
Fitting Chemigem to Commercial Systems	22
OPERATION	
Introduction	23
Reading the Display Panel	23
What is ORP	24
Password	24
Before Starting the Chemigem	25
The First Two Weeks	25
Regular Checks on the Quality of Pool Water	26
Regular Checks of the Tubing	26
To Avoid the Risk of Electric Shock	26
Electric Clock	26
Dosing of Chemicals	26

KEYPADS

1:	“ Pump”	27
2&3:	“Auxillary”	27
4:	“Escape and Mute Alarm”	28
5:	“Help”	28
6:	“Enter”	28
7&8:	“Automatically Increase & Decrease Pool Acid Set Levels”	28
9&0:	“Automatically Increase & Decrease Chlorine Set Levels”	29
A:	“Chlorine Manual Feed”	29
B:	“Pool Acid Manual Feed”	30
	Emptying Swimming Pool and Freezing Conditions	30
	Turning On and Off the Chlorine and Pool Acid	30
	Manual Dosing Override	31
	Calibrating the Unit	31
	Re-calibrating Chlorine	32
	To Change the Clock Time	32
	To Set the Date	32

POOL PUMP TIMER

	Setting the Inbuilt Pool Pump Timer	33
	Pump On Manually	33
	Pump Off Manually	33
	Pump Automatic On and Off	33
	Changing the Automatic Pool Pump Times	34
	Pump Off - Changing Period Setting	35
	Automatic Pump Timer Setting	35

ALARMS

	Indicator Light and Sound	36
	The Normal Range	36
	Outside the Normal Range	36
	Alarm Light and Sound - Steps to Take	36

CHEMICALS

	Chemical Feeding	37
	Adjustments to Chemical Levels	37
	Important Points to Note	38
	Pool Chemical Dilutions	38

PROBLEM SOLVING

	Low Chlorine Alarm	40
	High Chlorine Alarm	40
	Low pH Alarm (excess Acid)	41
	High pH Alarm (insufficient Acid)	41
	Cleaning the Multi-electrode	41
	Problem Solving Flow Chart	42

	Commercial Warranty	43
--	---------------------------	----

	Index	44
--	-------------	----

NOTES

Manually Operation	33
Automatic Operation	33&34
Period Settings	35
Pool Water	
Circulation	6
Quality	26
Problem Solving	
Chemical Levels	37
Low and High Chlorine Alarm	40
Low and High pH Alarm	41
Cleaning the Multi-Electrode	41
Flow Chart	42
PVC Tape	9
Safety Instructions	3&4
Sinker Sets	8
Solenoid Valves	
Multiple Sets	9
Valve Installation	15
Tubing Installation	15
Diagram	21&22
Tapping Band	
Operation	7
Multiple Sets	10
Air Leaks	11
Installation	12&17
Drill and Tap	12,13,18&19
Minimum Pressure	12
Inner Shell	12
Test Kit	5,9&24
Tools Required	8
Tubing	26
Venturi Systems	14
Warranty	43

IMPORTANT SAFETY INSTRUCTIONS

CAREFULLY READ THE ENTIRE CONTENTS OF THIS MANUAL

CAREFULLY READ THE FOLLOWING POINTS BEFORE INSTALLING THE CM 55 CHEMICAL CONTROLLER

WARNING It is important that the Chemigem is installed and operated in accordance with the instructions provided in this manual.

WARNING To reduce the risk of injury, do not permit children to use this unit unless they are closely supervised at all times.

WARNING To reduce the risk of electric shock, replace damaged cord immediately.

WARNING To reduce the risk of electric shock, do not use extension cord to connect unit to electric supply; provide a properly located outlet.

WARNING There is the risk of electric shock. Ensure all connections from the Chemigem to the electricity supply are made in accordance with local safety codes.

WARNING Do not bury any electricity supply cords unless strictly following local safety codes. Locate all cords, wires and tubes away from places where they may become damaged by garden equipment.

WARNING The Chemigem contains microprocessors that may be disturbed by the operation of electrical devices within a 6 metre radius.

WARNING The Chemigem must be connected so that it only operates when the pool pump is running, otherwise incorrect pool water readings will occur and concentrated chemicals may flow into the pool water pipes and/or the chemical drums, where they can mix and produce poisonous Chlorine gas.

WARNING Before operating the Chemigem, bring the pool water chemical levels to within the ranges given in this manual, but pay attention to the specific requirements of the pool builder.

WARNING To ensure the desired chemical levels are being maintained, check the pool water with a good quality test kit. This should be performed daily for the first two weeks and on a regular basis thereafter.

WARNING Always take water samples from a point near the skimmer box, for this is where the water is completely mixed, giving the most accurate readings. Never take water samples near the pool returns (“eye-balls”) where the Chemigem may have freshly dosed the pool water.

WARNING It is very important that the reagents in the test kit are well within their use-by date, otherwise false readings may result. If in doubt, take a water sample to a pool shop for testing.

WARNING Chemicals must be carefully diluted according to the size of the pool or spa. Always add the concentrated chemical to the water and never add the water to the concentrated chemical. Some chemicals react violently with water and can splash into face and eyes.

Always wear protective face-shield and gloves for such operations. Fully observe all the chemical manufacturer’s safety instructions when handling pool chemicals.

WARNING Ensure the chemical supplies (liquid Chlorine and pool Acid) are kept in visually different containers to avoid wrong connection. Use colour or size differences or both. When these two concentrated chemicals are mixed together out of the pool water, poisonous gas is produced.

WARNING A qualified electrician must affix the electrical outlet (housing the power to the pool) and, if required, to hard-wire the unit to the power source.

WARNING If it is decided to turn off the Chemigem audible alarm for any reason, the unit will no longer have that warning capability and the pool owner will have to rely on their own ability to monitor the indicator lights on the face of the unit to verify that the Chlorine and pH levels are within acceptable limits.

SAVE THESE SAFETY INSTRUCTIONS

Electricity - Asvoiding Shock	11&26
Emptying Swimming Pool	30
Face Shield and Gloves	9&25
Filters	8
Freezing Conditions	30
Heated Pool	6,14&21
Installation Below Pool Water Surface Level	14&20
Keypads	
No.1 “Pump”	27
No2 & 3 “Auxiliary”	28
No 4 “Escape” and”“Alarm Mute”	28
No 5”“Help”	28
No 6 “Enter”	28
No 7 & 8 “Increase And Decrease Acid Levels”	28
No 9 &0 “Increase And Decrease Chlorine”	29
No A “Chlorine Manual Feed”	29
No B “Pool Acid Manual Feed”	30
Metal Box	8
Multi-electrode	
Operation	7
Installation	13
Cleaning the Multi-Electrode	41
Neatening Up	14
Options Available	
Solenoid Valves	9
Computer Link	9&10
Temperature Monitoring	9&10
CO2, Acid & Alkali Control	9
Chlorine Gas	9
Delivery Systems	9
Password	24
Peristaltic Pumps	15
Plastic Tubing	7
Pool Pump	
Times	5
Setting Timer	33

INDEX

Alarms	
Safety Signals	36
Normal range	36
Steps To Take	36
Balancing Pool Water	5,24&26
Chemicals	
Chlorine and pH Numbers	23&37
ORP	23&37
Before Starting the Chemigem	24&25
Suggested Chemical Ranges	25&37
Dosing	26
Turning On and Off Chlorine and Pool Acid	30&31
Manual Dosing Override	31
Chemical Feeding	37
Chemical Drums Installation	13
Chemigem DM55	
Operations	5&23
Key Features	7
Location	11
Installation	11&16
Introduction	23
Chemical Settings	23
Before Starting the Chemigem	24
The First Two Weeks	25&26
Calibrating the Unit	31
Important Points To Note	38
Pool Chemical Dilutions	38&39
Low and High Chlorine Alarm	40
Low and High pH Alarm	41
Clock Time	32
Contact Pool Controls	6
Date on Chemigem	32
Display Panel	
Reading the Display Panel	23
Left and Right Side of Panel	24

MESSAGE TO THE NEW OWNER

Congratulations on your purchase of a CM55 Chemigem Commercial Chemical Controller

Prior to Installation and Operation

It is important that a full water test is carried out with a good quality test kit and that the pool water is correctly balanced prior to the installation and operation of the Chemigem.

The pool builder often includes the first amounts of chemicals. These are estimated and sometimes require adjustment.

Chemigem Operation

The unit is one of the most advanced pool chemistry controllers of its kind and provides a degree of chemical consistency that cannot in all practicality be achieved by manual testing and dosing.

It is important that it is installed and operated in accordance with the instructions provided in this manual.

The Chemigem is designed to automatically assist in keeping the levels of Chlorine and pH correctly balanced in swimming pools and spas and can cope with extreme variations in bather load that is experienced in commercial pools.

The unit continuously monitors and adjusts pH and Chlorine levels while the pool pump is running, as and when required.

Stable controlling of the Chlorine and pH levels of the pool water should be achieved during the first two weeks of operation. During this period, check the level of Chlorine, Total Alkalinity and pH regularly with a good quality test kit to confirm that the unit is keeping to the desired levels (Refer to pages 25&37).

The chemical levels are set by the keypads. Once the correct positions have been set for the pool water they should remain constant and do not have to be changed from season to season (however in winter the pool pump running times can be reduced)

The unit has been factory-set to achieve 650 millivolts Chlorine (ORP) and 7.7pH as the preferred levels for Chlorine and pH respectively. (Refer to page 23)

Electronic Clock

The in-built electronic clock requires setting to your local time. (Refer to page 32)

Pool Pump Times

The factory-set pool pump times are referred to on page 33. To change pumping times or to turn the timer off refer to pages 33 to 35.

Pool Water Circulation

To enable the Chemigem to work efficiently, the mixing of the pool water has to be as quick and complete as possible. Positioning the return nozzles (eyeballs) to the pool so that the main water-body rotates is the best way to achieve this. Under no circumstances should the eyeballs be positioned to produce opposing circulation patterns. The unit's Multi-electrode monitors the Chlorine and pH levels as the water travels towards the pump.

If the mixing of the pool water is slow, the Multi-electrode will not receive the signal until large amounts of chemicals have been added to the water. When the Multi-electrode finally receives the signal, the pool water may be overdosed and the excess warnings will operate.

Heated Pool

If the one pool pump is required to service both the filter and the pool heating system, the pool heating plumbing must be bypassed. (Refer to pages 14&21)

CONTACT POOL CONTROLS

Pool Controls Pty Ltd assembles and supplies the CM 55 Chemigem Commercial Chemical Controller

If problems are encountered in the installation or operation of the unit and the problems persist after checking the Problem Solving suggestions and other relevant sections of this manual, contact Pool Controls.

Pool Controls contact details are:

Phone: (+618) 9344 7044
Fax : (+618) 9345 1816
E-mail: sales@pool-controls.com.au
Address: 251 Balcatta Rd, Balcatta 6021 Western Australia
Website: www.pool-controls.com.au

COMMERCIAL WARRANTY

REPLACEMENTS

COMPONENTS OTHER THAN THE MULTI-ELECTRODE

Pool Controls undertakes to rectify, free of charge, any defects caused solely by faulty workmanship or materials occurring in the Chemigem control unit for a period of 12 months

MULTI-ELECTRODE

The multi-electrode has a 12 months full cover warranty.

SERVICING IN THE WARRANTY PERIOD

In the event of any apparent malfunction during the Warranty period, the purchaser of the Chemigem should first read the Installation and Operating Manual. If this does not solve the problem, Pool Controls should be contacted.

FEES

During the warranty period, when an authorised technician is requested to service the unit at a location other than the company premises, a call out fee will be charged to cover travelling to and from the site and the cost of operating the vehicle. The fee will not apply if the unit is returned to the manufacturer or distributor in your state for repairs.

If an authorised technician is required to service the unit and it is found that such services are not covered by warranty, a charge for parts and labour will apply.

Where the unit is installed outside the normal service area, the purchaser shall be responsible for all costs and risk involved in returning the unit to the manufacturer for repairs and reinstallation.

WARRANTY EXCLUSIONS

Pool Controls accepts no responsibility under this Warranty for damage including:

- Consequential damage resulting from misuse of the Chemigem
- Incorrect usage of the Chemigem
- The use of other than Chemigem parts
- Installation or repair in any way such that the performance or working life expectancy of the Chemigem is impaired

The liability under this Warranty shall not include any costs, contingent or otherwise, or liability for damage sustained by the customer or others, whether or not these costs or damages are due to the malfunction, wrong operation or actions by Pool Controls or the authorised representatives of Pool Controls, but shall be limited solely to the repair or replacement of the product

POOL CONTROLS EXPRESSLY DISCLAIMS ANY OTHER EXPRESS OR IMPLIED WARRANTIES INCLUDING THE IMPLIED WARRANTY OF MERCHANTABILITY OR FITNESS FOR A PARTICULAR PURPOSE.

PROBLEM SOLVING FLOW CHART

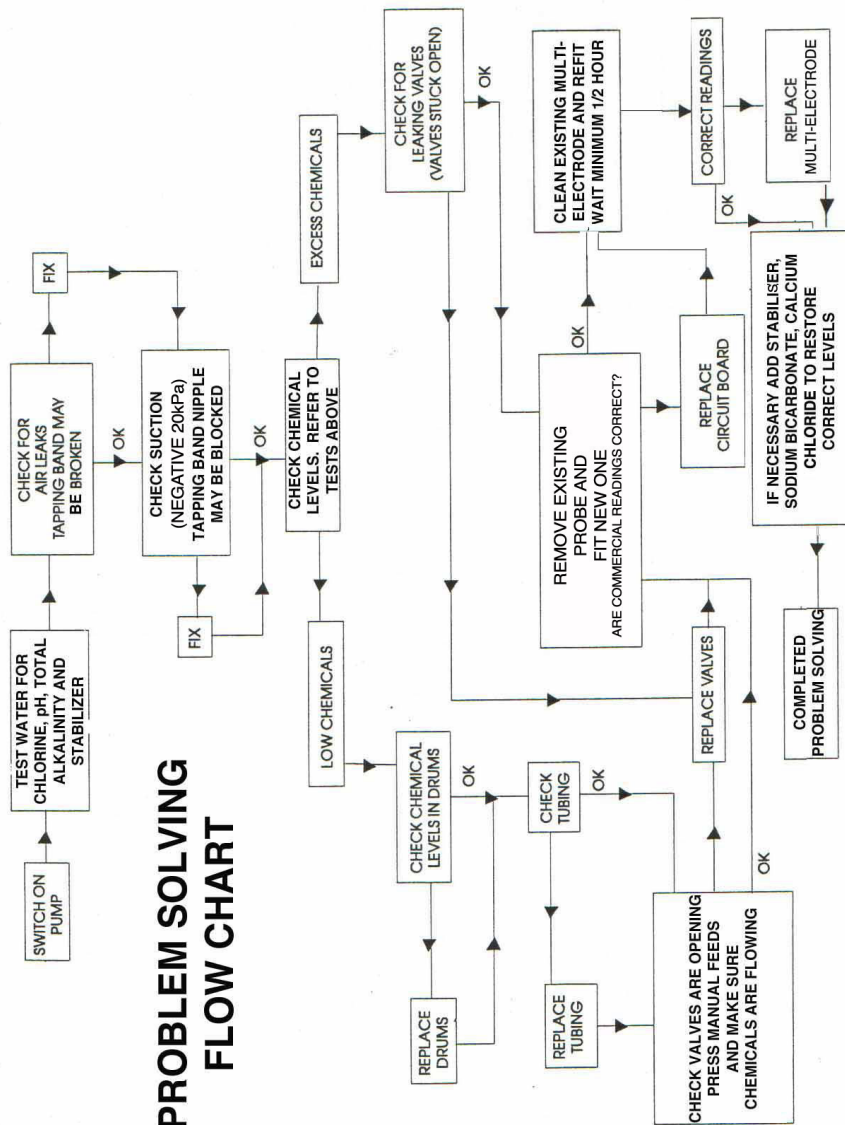

PREPARATION

ITEMS SUPPLIED

A brief description of the items supplied and the purpose of each item:

CM 55 Chemigem Commercial Chemical Controller

The sealed unit is connected to an injection system that assists in keeping the levels of Chlorine and pH correctly balanced in swimming pools and spas. (Refer to diagram on page 16)

Key features:

- A see-through protective faceplate covering the front of the unit
- A computerised on-screen **HELP** menu
- An automatic pool pump timer
- An easy-to-read screen showing chemical settings and actual chemical readings
- Indicator light and audible alarm that monitor whether pool water chemical levels are within the required range

Multi-electrode

The Multi-electrode is fitted inside of the Tapping Band that is then inserted directly into the PVC pipe running from the pool.

The one Multi-electrode monitors both the Chlorine and pH levels.

The Tapping Band is on the inlet (suction) side of the pool pump.

Chemical readings obtained by the Multi-electrode are monitored by the Chemigem, resulting in Chlorine and/or pool Acid being dosed into the pool water as and when required. (Refer to diagram on pages 16)

Tapping Band

The Tapping Band is inserted into the PVC pipe on the inlet (suction) side of the pool pump. (Refer to diagram on page 16)

A detailed diagram of a Tapping Band is provided on page 17.

The purpose of the Tapping Band is to house the Multi-electrode and to provide an injector nozzle for chemicals being dosed into the pool water.

Coil of Plastic Tubing

The plastic tubing is connected from the delivery system to the chemical drums and the Tapping Band. (Refer to diagram on page 16)

Filters

There are two types of filter:

- In-Line Filter
- Drum Filter

The In-Line Filters are connected to the plastic tubing for both the Chlorine and pool Acid tube lines, between the respective chemical drums and the Solenoid Valves.

The Drum Filters are connected to the plastic tubing. One is placed in the Chlorine drum and the other is placed in the pool Acid drum.

(Refer to diagram on page 16)

Sinker Sets

The Sinker sets are fitted above the Drum Filters. The purpose of the sinkers is to provide added weight to the Drum Filters so that the filters do not float and are positioned close to the bottom of the chemical drums. (Refer to diagram on page 16)

Metal Plate

The metal plate is affixed to a solid surface in a sheltered location. The Chemigem fits onto the metal plate.

TOOLS REQUIRED

The following is a list of tools required together with the purpose for each tool:

19mm Hole Saw

To drill a hole in the PVC pipe for the fitting of the Tapping Band. (Refer to diagram on page 17).

A hole saw can be purchased from most hardware stores

Spirit Level

For fitting the Chemigem horizontally to a solid surface. (Refer to diagram on page 16)

Electric or battery charged drill

For drilling screws to hold the Chemigem and Solenoid Valves

Drill Bits

- Masonry drill bit for wall anchors.
- For holes in the lids of chemical drums (Refer to diagram on page 16)

Screwdriver

For affixing self tapping screws

Tape Measure

To measure for the location of Chemigem components

Spanner

For tightening the Tapping Band. (Refer to page 12)

Electrician's Tools

If the unit is to be hard-wired, the electrician will require tools to wire the Chemigem and pool pump.

LOW pH ALARM (Excess Acid)

This indicates that the pH level in the water is considerably lower than that which was set. The Chemigem cannot do anything about this condition except warn about it. However as a safeguard, the unit operates a lock on any more additions of Acid (that would only make matters worse) until the pH is brought back into the normal range with the addition of some Sodium Carbonate or Sodium Bicarbonate- "Buffer".

Low pH levels could be due to the following:

- Manual overdosing with pool Acid
- Poor pool water circulation leading to over-dosing.
- Excessive rainfall (that is slightly acidic) neutralising the alkalinity of the pool.
- A faulty Solenoid Valve.
- Multi-electrode requires cleaning (Refer to Cleaning Instructions below)

HIGH pH ALARM (Insufficient Acid)

This indicates that the pH level in the water is considerably higher than that which was set. In this case the Chemigem will be in a locked condition and will not dose further pool Acid until the lock mechanism is overridden. This is carried out by pressing the **ESC** keypad No.4. The unit will then dose further pool Acid until the level for pH that was set has been reached.

High pH levels could be due to the following:

- Initial conditions in a new plaster lined pool being very alkaline and overwhelming the unit's ability to dose sufficient acid.
- The unit has a proportional acid setting that may have been adjusted to add insufficient acid
- The Acid drum may be empty
- Super chlorinating the pool
- The injector nozzle in the Tapping Band is clogged
- The venturi system (if fitted) is clogged
- A faulty Solenoid Valve
- The filter needs backwashing
- Multi-electrode requires cleaning (Refer to Cleaning Instructions below)

CLEANING THE MULTI-ELECTRODE

- Remove from the Tapping Band by unscrewing the retaining nut and pulling out the Multi-electrode
- Holding the cable, gently swirl the Multi-electrode sensing components in a dilute solution of Hydrochloric Acid (normal pool Acid) for a minute or two
- Rinse the Multi-electrode in clean water
- Replace the Multi-electrode, making sure the "O" seal is in place
- Screw up the nut with fingers only. (Refer to page 13)

PROBLEM SOLVING

LOW CHLORINE ALARM

This indicates that the Chlorine level in the pool water is considerably lower than the level that was set.

The Chemigem will restore the level by feeding Chlorine approximately every 3 minutes until the set level is reached again (however feeding may be inhibited by one of the factors listed below). As the Chlorine level in the water approaches the set level, the warning sound and the red warning light will switch off, but the warning sound may be switched off at any time by pressing the **ESC** keypad No.4. This sound will come on again the next time the pool pump operates if the Chlorine level is still too low.

Low Chlorine levels could be due to the following:

- Excessive bather load
- The Chlorine drum is empty
- Increasing the set level by a large amount
- The filter has been off for a long period on a hot day
- The Stabiliser level is too low
- The pH is too high
- The filter requires backwashing
- The strainer (part of the pump) requires cleaning out.
- Inadequate pool water circulation
- The injector nozzle in the Tapping Band is clogged
- The venturi system (if fitted) is clogged
- A faulty Solenoid Valve
- MULTI-ELECTRODE requires cleaning (Refer to page 12)

HIGH CHLORINE ALARM

This indicates that the Chlorine level in the pool is considerably higher than that which was set. Should this be due to an intentional overdose (super chlorination or shock treatment) it may be some days or even weeks before the level drops and the warnings turn off.

High Chlorine levels could be due to the following:

- Manual overdosing with Chlorine
- The pH is too low (too much pool Acid)
- Changing the set level to a much lower setting
- High total dissolved Solids (TDS) level (above 2000 ppm)
- Inadequate pool circulation
- The Solenoid Valve is faulty
- Multi-electrode requires cleaning (Refer to page 41)

OTHER ITEMS REQUIRED

Other items required together with a brief description of the purpose of the items:

Pool Water Test Kit

A good quality test kit is essential for testing the pool water.

The pool water must be tested and balanced before the Chemigem is turned on.

Chemicals

Refer to pages 37 to 39

PVC Tape

For use on the chemical drums, solenoid tubing and loose wires. (Refer to pages 13&15).

Protective Face Shield and Gloves

For use when diluting chemicals. (Refer to page 25)

OPTIONS AVAILABLE

The Chemigem has a number of options available at an additional cost.

The options need to be selected prior to the purchase of the unit.

Not all of the options are shown below, due to the complexity and the wide divergence of option alternatives.

Options Available:

- Sets of Solenoid Valves for each pump and filter (Refer below and to page 23)
- Computer link with RS485 to work with Windows 95/98 (Refer to page 10)
- Temperature monitoring (Refer to page 10)
- CO₂, Acid or Alkali control for pH
- Control of Chlorine gas
- Various delivery systems

Set out below is a brief overview of the more common options that are utilised:

Sets of Solenoid Valves for Each Pump and Filter

(Refer to diagram on page 22)

A maximum of four sets of Solenoid Valves can be provided, one for each pump and filter.

If multiple sets of solenoid valves are used, a Valve Junction Box may be required. The Valve Junction Box is connected to the Chemigem, with each set of Solenoid Valves connected to the Valve Junction Box.

If one or more pool pumps are turned off (as may occur in colder months), the electrical lead to the Solenoid Valves (that would normally service the turned off pool pump) should be disconnected at the same time from the top of the valve pack.

If the pipe size is 40mm or 50mm, Tapping Bands are fitted to each pump and filter. The pumps and filters without a Multi-electrode but with the injector nozzle feature will be supplied with a cap to block off the fitting that normally houses the Multi-electrode. (Refer to page 22)

If the pipe size is more than 50mm, a Drill and Tap installation for the single Multi-electrode and multiple injector nozzles is required (Refer to page 13 and to the diagrams on pages 18&19)

Computer Link with RS485 to Work with Windows

The option provides a direct connection to a PC and other devices such as a printer, remote control panel and output modules (for example, 4-20MA)
 The network connection uses "MODBUS" protocol for communication and can be used for interfacing the Chemigem to PLC's, BMS etc.
 The network connection can also be used to connect a maximum of 32 Chemigem Commercial Chemical Controllers so as to directly monitor and control the operation of the units from a central location.

Temperature Monitoring

The Multi-electrode (in addition to monitoring Chlorine and pH levels) can also monitor pool water temperature.

Chlorine

The Chemigem is designed to automatically help keep the correct level of Chlorine (and pH) in pool water by continuously monitoring the water chemistry while the pool pump is operating. Chlorine (and pool Acid) is dosed into the pool water as and when necessary.

The Chlorine in common use is a sodium hypochlorite solution. The Chemigem uses this chemical.

Diluting Chlorine is strongly recommended as follows:

- Pools larger than 90kl 20 litre drum or larger full strength
- 20kl - 90kl 20 litre drum full strength.
- 10kl - 20kl 20 litre diluted 1:1 with water
- Spas 2kl - 10kl 20 litre diluted 1:15 with water
- Spas less than 2kl 10 litre diluted 1:20 with water

IMPORTANT POINTS TO NOTE

- Adding chemicals will take only a few minutes but removing the chemicals depends upon the natural dissipation from the pool water, which could take weeks
- Add pool chemicals slowly and with appropriate care, allowing sufficient time for complete dissolving and mixing throughout the pool water and then carry out water tests to determine whether the correct amounts have been added
- Take samples at a point near the skimmer box, for this is where the water is completely mixed, giving the most accurate readings. Never take samples near the pool returns (eyeballs) where the Chemigem may have freshly dosed the pool water
- Do not overdose the pool water with either Chlorine, pool Acid or Stabiliser
- pH is lowered by the addition of pool Acid
- Excess pool Acid (low pH) is neutralised with Sodium Carbonate (strong) or Sodium Bicarbonate (less strong)-("Buffer")
- Excess Chlorine is neutralised with Sodium Thiosulfate
- Excess Alkalinity is neutralised with Non-Fuming Pool Acid (dilute sulphuric acid) or Hydrochloric acid (Muriatic acid)

POOL CHEMICAL DILUTIONS

Pool Acid

The Chemigem is designed to automatically help keep the correct level of pH (and Chlorine) in pool water by continuously monitoring the water chemistry while the pool pump is operating. Pool Acid (and Chlorine) is dosed into the pool water as and when necessary.

There are two kinds of pool Acid in common use and the unit is able to use both:

- Hydrochloric Acid (muriatic acid).
- Non-Fuming Pool Acid (dilute sulphuric acid)

It is strongly recommended that the non-fuming pool Acid be used because the Hydrochloric acid gives off corrosive and highly irritating fumes in its concentrated form. It must be kept at least 6 feet from the unit unless diluted at least 5 to 1 with water.

Diluting Pool Acid is strongly recommended as follows:

- Pools larger than 90kl 15 litre drum, full strength
- 50kl - 90kl 15 litre diluted 1:5 with water
- 10kl - 50kl 15 litre diluted 1:10 with water
- Spas/pools 2kl - 10kl 15 litre diluted 1:15 with water
- Spas less than 2kl 15 litre diluted 1:20 with water

IMPORTANT Always add concentrated Acid to the water not the water to the concentrated Acid. Small quantities of water will react violently with concentrated Acid, giving off heat and boiling the water that may splash Acid.

INSTALLATION

LOCATION

For ease of installation and for safety, the Chemigem Commercial Chemical Controller must be installed as follows:

- In a normal upright position (with the printing on the front reading horizontally) and protruding cords facing toward the ground
- Attached to a solid vertical surface to provide easy access to the power supply and should preferably be fixed at eye level

To obtain maximum life for the unit it is recommended that it be located in a sheltered and shaded position.

(Refer to pages 14,20&21) for the special procedures required for the placement of the Chemigem when the pool pump and filter are located below pool water surface level and when the pool has a heater unit)

Devices such as mobile phones, radios and portable CD players, are capable of emitting radio waves that may interfere with the correct operation of the Chemigem. Avoid using these devices within a radius of 6 metres.

To Avoid the Risk of Electric Shock

- Replace damaged cord immediately
- Do not use extension cord to connect unit to electric supply. Provide a properly located outlet.

CHEMIGEM INSTALLATION

Position the Chemigem within 2.5 metres of the Tapping Band at a convenient height for easy operation, preferably at eye level. (Refer to diagram on page 16). If it is impractical to install the unit at eye level because of site restrictions, install it at any height that provides ease of access and operation in a normal upright position (with the printing reading horizontally and protruding cords facing toward the ground).

TAPPING BAND INSTALLATION

Air Leaks

Before commencing the installation of the Tapping Band, check for air leaks in the suction line by switching on the pool pump and checking the 'strainer'. If there are a lot of air bubbles swirling around which do not clear within 2 to 3 minutes, it is likely the system has an air leak in the suction line between the pool and the pool pump.

If a pool-cleaning device is in use, carefully check the flexible hose for small pinholes that allow the entry of air into the suction line.

Installation

A Tapping Band installation is required for pipe sizes of 40mm and 50mm. Pipe that is more than 50mm requires a “Drill and Tap” method for fitting the Multi-electrode and injector nozzle. (Refer to page 13 and diagrams on pages 19&20)

Turn off the pool pump before commencing the installation of the Tapping Band. Refer to the diagram on page 17 :

- The components to be connected to the PVC pipe
- The connection of the Multi-electrode to the Tapping Band
- The location of the Multi-electrode and Tapping Band

It is imperative to fit the Tapping Band to the inlet (suction) side of the pool pump.

The required minimum negative pressure/suction is negative 20 kPa.

In selecting the position for the Tapping Band on the pool pump inlet pipe, ensure that it is as near as possible to the pool pump.

When the Chemigem is working it is essential that the Multi-electrode and injector nozzle be in a rapidly moving water stream. If not, the unit will display incorrect and erratic readings and may cause additions of concentrated chemicals.

The Tapping Band can be positioned on either horizontal or vertical pipes, provided the Multi-electrode is fitted **exactly horizontally**.

- If the Multi-electrode is positioned with the sensor tips aiming downwards it will trap air bubbles
- If the Multi-electrode is positioned with the sensor tips aiming upwards it will trap dirt or debris

Both of these positions will cause erratic and false readings of the swimming pool chemical levels.

Drilling the Tapping Band Holes

- Drill a hole using a 19mm hole-saw through both sides of the PVC pipe
- Ensure the surround to the hole at the “O” ring contact is smooth and clean
- Fit the Tapping Band, first checking that the “O” rings are in position and that the arrow on the Tapping Band points **toward** the pool pump

Do not use grease or sealing compound on this fitting.

To check the accuracy of the Tapping Band position look through the Multi-electrode arm (feel with your finger or use a mirror if the position is inaccessible) making sure the Multi-electrode is lined up exactly with the holes. Tighten by hand and then give the nuts half a turn with a spanner. If the Tapping Band is over tightened it will split. (Refer to diagram on page 17)

Inner Shell of Tapping Band

The inner shell of the Tapping Band is used if the PVC pipe has a 40mm diameter. If 50mm diameter PVC pipe is used, the inner shell of the Tapping Band is not required. (Refer to diagram on page 17).

CHEMICALS

CHEMICAL FEEDING

Depending upon how the unit has been programmed, the standard procedure is that the first time that the unit operates it will take approximately 120 minutes to fully adjust to the required levels of Chlorine and pH. Thereafter it will normally restore the required levels in approximately 30 minutes.

Ensure that the pool pump is running for a sufficient period to carry out these adjustments.

ADJUSTMENTS TO CHEMICAL LEVELS

The day following the installation of the Chemigem and after the pool pump has been running for 30 minutes, check the level of Chlorine and pH with a good quality test kit. If either of the levels is not exactly at the levels required, alter the settings a little with keypads 7 and 8 or 9 and 0. The Chemigem will bring about the changes to the chemistry of the pool water as the pool pump circulates the water.

It is suggested that swimming pool water should be maintained within the following ranges and that these ranges are confirmed with your local authorities as meeting their standards:

• CHLORINE	1.0 to	3.0 ppm
• pH	7.2 to	7.8
• CALCIUM HARDNESS	100 to	200 ppm
• STABILISER	30 to	50 ppm
• TOTAL ALKALINITY	80 to	200 ppm
• TOTAL DISSOLVED SOLIDS (TDS)	300 to	2000 ppm

The Chemigem will work at maintaining Chlorine (ORP) levels within a range of 600 - 700 millivolts when set at 650 and pH levels within 0.2 pH units of that set.

It has been found that if ORP is maintained at 650 millivolts, the kill time of E-coli type bacteria is about one second.

If the ORP is lowered to 550 millivolts, the same organisms could take up to 2 hours to be eliminated.

The pH scale runs from 1 to 14, with 1 being strongly acid and 14 being strongly alkali.

Pool water should be between pH 7.2 and 7.8 (which is almost neutral) so it is not harmful to humans.

pH values at the upper and lower ends of this scale are **very dangerous**.

pH is also very important in keeping pool surfaces from degrading too rapidly. Too much acid (too low a pH value) will cause plaster surfaces to degrade quickly. The unit is factory - set to help maintain pH at 7.7 to keep the pool plaster in good condition.

If after a few days the unit is not able to keep within these ranges, consult the Problem Solving pages 40 to 41 in this manual and/or contact the supplier of the Chemigem or a qualified pool maintenance technician.

ALARMS

INDICATOR LIGHT AND SOUND

The safety warning sounds and alarm signals will not operate for the first 4 minutes.

THE NORMAL RANGE

When the pool pump is running the Chemigem shows a green light if the pool chemical levels are within the normal range.

To ensure the unit is maintaining the pool water at the required levels, check the pool water on a regular basis with a good quality test kit.

The unit operates to keep the activity of Chlorine in the pool at a level where micro-organisms are killed in about 1 second. For this to happen both the Chlorine (ORP) and pH must be kept within a fairly narrow band. (Refer to page 23)

OUTSIDE THE NORMAL RANGE

If the levels of chemicals move outside the optimum band the Chemigem will indicate this in two ways.

- It will sound an alarm, provided the alarm is switched on.
- The red light will flash at one-second intervals.

When the alarm is sounding and the red light is flashing the unit will also indicate on the screen the reason for the alarm.

This booklet contains sections on what remedial action to take should the warnings operate.

ALARM LIGHT AND SOUND - STEPS TO TAKE

Alarms must not be ignored. Immediately investigate the causes and until it is certain that the pool water is safe, do not use the pool. Seek professional help from a qualified pool maintenance technician if it is not fully understood what is happening.

- Read the message on the screen. This will advise which chemical is out of the normal range
- Make a test of the pool water with a good quality test kit to check if the Chemigem has the same readings
- It is very important that the chemical reagents in the test kit are well within their use-by date. If in doubt, take a fresh sample of pool water to a pool shop for an independent test
- If the Chlorine is too low, or the pH too high, check the drums of chemical to determine whether they have run out
- If the Chlorine is too high or the pH too low, switch off the one that is incorrect and as an extra precaution, remove the tube from the drum and place it in a bucket of water

Consult the Problem Solving section on pages 40 to 41 for suggestions on how to deal with chemical excesses.

DRILL AND TAP INSTALLATION

(Refer to diagrams on pages 18&19)

The "Drill and Tap" method for fitting the Multi-electrode and injector nozzle is used when the pipe size is more than 50mm. (For pipe that is 40mm or 50mm, a Tapping Band is fitted. Refer to page 12)

There are two separate installations for the "Drill and Tap" method:

- One for fitting the Multi-electrode
- One for fitting the Injector Nozzle

When drilling and tapping, select a position where the work can satisfactorily be carried out on the pool pipe.

The recommended minimum distance between the Multi-electrode and the Injector Nozzle is 60mm. The Injector Nozzle is fitted between the Multi-electrode and the pool pump.

MULTI-ELECTRODE INSTALLATION

- Remove the Multi-electrode protective cap before fitting the Multi-electrode to the Tapping Band (Refer to diagram on page 17).
The protective cap should be retained for possible future use. (Refer to page 30)
- Fully insert the Multi-electrode (with "O" ring fitted) into the Tapping Band and **hand tighten only.**

Do not use grease or sealant on this connection. (To avoid contaminating the sensing part of the Multi-electrode.)

CHEMICAL DRUMS INSTALLATION

Ensure the Chlorine and pool Acid are kept in visually different drums to avoid wrong connection. Use colour or size differences, or both.

Refer to the cutaway diagram of chemical drum on page 16 for a presentation of the following:

- Position the Chlorine and Acid drums in a safe and secure location about 2 metres from the Chemigem
- Drill a hole in each of the screw-on drum caps (slightly larger than the diameter of the tubing) to prevent the drum walls from being sucked in as the chemicals are used
- Pass each length of supplied tubing through the hole in the appropriate drum cap
- Place the supplied sinkers onto the tubing and attach the appropriate drum filter (Refer to page 8)
- When placing the tubing into the drums, measure the tubing against the outside of each drum so that the drum filter will be 2cm above the bottom of the drum and then apply several turns of PVC tape at a point above the cap to prevent the tubing from slipping further into the drum
- Lower the drum filter and sinker into the drum and screw on the cap
(Refer to pages 38&39 for pool Acid dilution details.)

FITTING CHEMIGEM TO A HEATED POOL

If one pool pump is required to service both the pool heating system and the filter, the pool heating plumbing must be bypassed. This will necessitate the installation of a Venturi system at an additional cost. (Refer to diagram on page 21)

FITTING CHEMIGEM BELOW POOL WATER SURFACE LEVEL

The following instructions assume the installer has some knowledge of the operation of the pool and the parts described. If the installer is not experienced in pool operation and maintenance, contact the supplier of the Chemigem or a qualified pool maintenance technician with any questions before attempting to carry out the steps described in this section.

The Chemigem must be installed within 2.5 metres of the Tapping Band and in an upright position and attached to a solid vertical surface, preferably at eye level. If it is impractical to install the unit at eye level because of site restrictions, install it at any height above the Solenoid Valves that provides ease of access and operation. The Solenoid Valves need to be above the height of the chemical drums.

When the pool pump and filter are fitted below the pool water surface level, the suction line may be under positive pressure even with the pump running. In this case an isolating valve **must** be fitted to enable the pump and filter to be serviced. Fit the Tapping Band between the isolating valve and the pool pump and close the isolating valve sufficiently to obtain the required suction so as to allow the unit to operate effectively.

Minimum suction is negative 20kPa when the pool pump is running and the filter is clean.

Methods to obtain improved suction involve using venturi devices or orifice plates. Contact the supplier of the Chemigem or a qualified pool maintenance technician for information on these.

If the pool pump is more than one metre below the pool water surface it is essential to fit Non Return Valves into the chemical supply tubing to prevent back-flow into the chemical drums.

Failure to prevent the back-flow into the chemical drums would cause spillage from the drums, which in turn may result in the two concentrated chemicals mixing together out of the pool water and producing poisonous chlorine gas. In addition, there is the serious possibility of personal injury from contact with the chemicals and breathing the fumes.

(Refer to diagram on page 20)

VENTURI SYSTEM

A venturi system is required for:

- Special needs, such as fitting a Chemigem below the pool water surface level (Refer above)
- Pools that are heated (Refer above)

PUMP OFF – OR CHANGING PERIOD SETTINGS

The unit has been pre-set to **DAILY**

Press **ENTER**

TIMERS will flash on screen.

Press **ENTER**

Enter the pin number if **ENABLED**

PUMP will flash on screen

Press **ENTER**

Select **P1**

Press **ENTER**

START will flash on screen

Press **SELECT** with keypads A or B

The options can be seen in the top right hand side of the screen

Scroll through the different options using the **ENTER** keypad and select **OFF** to turn off the pump or the option required for a different period (Refer below for an explanation of the abbreviations)

Press **ESCAPE** 4 times to get back to the main menu

AUTOMATIC PUMP TIMER SETTINGS:

Daily	Every day
Mon	Monday only
Tue	Tuesday only
Wed	Wednesday only
Thu	Thursday only
Fri	Friday only
Sat	Saturday only
MO - SA	Monday to Saturday inclusive
MO – FR	Monday to Friday inclusive
MO – TH	Monday to Thursday inclusive
FR – SU	Friday to Sunday inclusive
FR – SA	Friday to Saturday inclusive
SA – SU	Saturday and Sunday inclusive
SU – FR	Sunday to Friday inclusive
OFF	Off

CHANGING THE AUTOMATIC PUMP START TIMES:

When changing the automatic pump times, ensure that the START time is less than the STOP time.

Changing HOURS

Press **ENTER**

TIMERS will flash on screen

Press **ENTER**

Enter the pin number if **ENABLED**

Select **PUMP**

Press **ENTER**

Select **P1**

Press **ENTER**

Select **START**

Press **ENTER**

Select **HOURS** using keypad B

Press **ENTER** to change the **HOURS** figure

Each time the ENTER keypad is pushed the hours will increase

If the required HOURS figure is bypassed, keep pressing the keypad until the desired time is reflected

Press **ESCAPE** 4 times to get back to the main menu

Changing MINUTES

After the desired **HOURS** are chosen, select **MINUTES** using keypads A or B

Press **ENTER** to select the desired **MINUTES**.

When the correct time is set using keypad A, select **OK**

Press **ENTER**

Selecting Additional Automatic Pump Times:

Select **P3 or P4**

Press **ENTER**

Select **START**

Press **ENTER**

Select **HOURS** using keypad B

Press **ENTER** to change the

HOURS figure

Each time the **ENTER** keypad is pushed the hours will increase

If the required **HOURS** figure is bypassed, keep pressing the keypad until the desired time is reflected

After the desired **HOURS** are chosen, select **MINUTES** using keypads A or B

Press **ENTER** to select the desired **MINUTES**.

When the correct time is set select **OK** using keypads A or B

Press **ENTER**

Press **ESCAPE** 4 times to get back to the main menu

Chemigem Pool Automation provides information on the installation procedure for a venturi system.

Chemigem Pool Automation provides the venturi system at an additional cost.

NEATENING UP

Finish the installation by taping all loose wires and tubing together and place off the ground to prevent damage and possible electrical shorting.

DELIVERY SYSTEMS AVAILABLE

Because a Chemigem can be supplied to operate in a variety of operational modes, information on peristaltic pumps will be supplied separately with this manual to suit the specific needs of the unit.

SOLENOID VALVES**Valve Installation**

- The valves must be fitted as near as possible to the Tapping Band (Refer to diagram on page 16)
- The valves must be screwed to a vertical surface, above the top of the chemical drums and no more than 75mm from the ground so that the pool pump may easily raise the chemicals from the drums

To meet special needs, a Venturi system can be connected to the Solenoid Valves. (Refer to page 15)

Tubing Installation

- Connect a length of tubing between the center nipple on the Solenoid Valve base and the Tapping Band injector nozzle
- Connect a length of tubing to the Chlorine in-line filter and lay it neatly to the Chlorine drum
- Connect a length of tubing to the pool Acid in-line filter and lay it neatly to the pool Acid drum

(Refer to diagram on page 16)

Ensure that the tubing is absolutely clean and free from sand and dirt before fitting, as particles may enter the valve and cause leakage.

Do not use any tubing other than that supplied. To do so may result in damage to the Chemigem and negate the Warranty. If additional tubing is required for the installation of the unit, it will be supplied at no cost.

CM 55 CHEMIGEM COMMERCIAL CHEMICAL CONTROLLER
INSTALLATION DIAGRAM USING SOLENOIDS

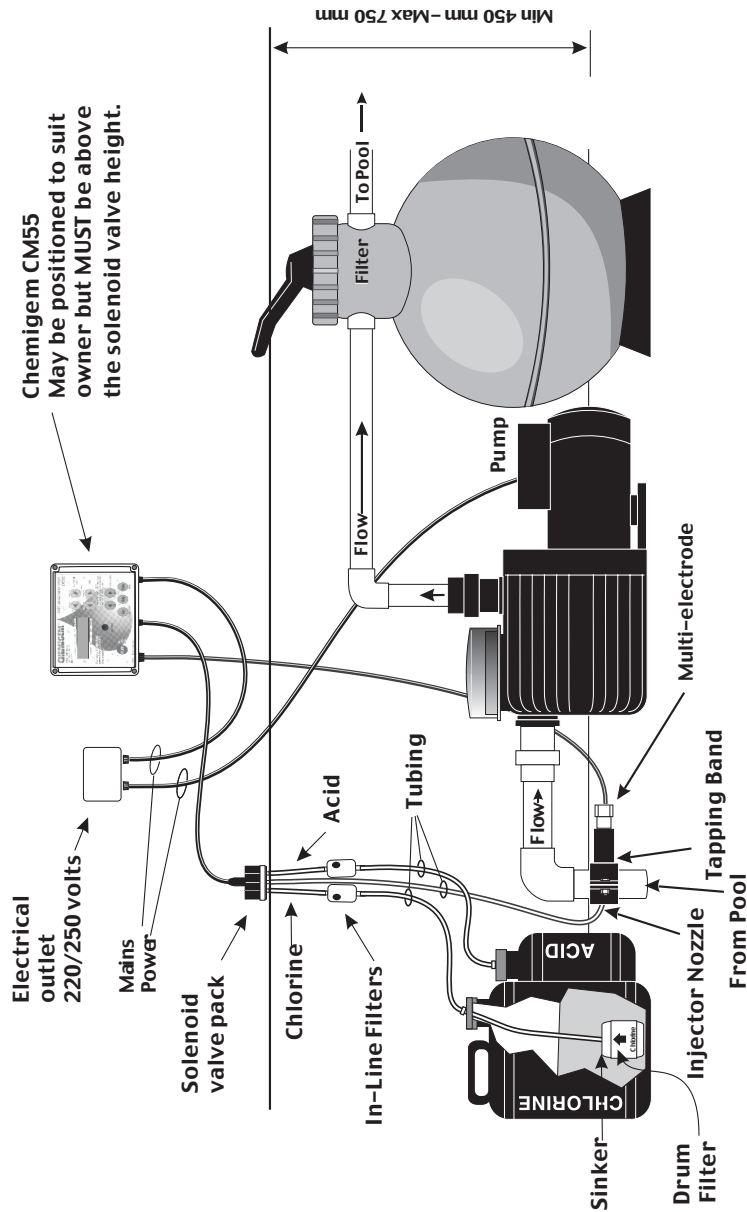

POOL PUMP TIMER

SETTING THE INBUILT POOL PUMP TIMER

The unit's built-in pump timer is factory set to two ON TIMES each day. If the built-in pump timer is not to be used (because an external pump timer is used), the built-in pump timer **must** be permanently turned off. (Refer below)
 If it is decided to turn off the automatic pool pump timer and use the manual switching of the pool pump on a daily basis, this may result in unbalanced pool water that is not safe for swimming. If necessary, obtain advice from a qualified pool maintenance technician.

PUMP ON MANUALLY

The following instructions apply if the unit's built-in pool pump timer is used, and not an a separate pool pump timer:

To turn the pool pump on manually for 30 minutes:

Press keypad 1 until the

ON light is illuminated

To increase the manual ON time:

Select

PUMP ON and continue to hold down. After 5 seconds the length of time to run manually can be seen in the top right hand side of the unit's screen. This will increase every few seconds. Release the keypad when the required length of time is reached.

PUMP OFF MANUALLY

The following instructions apply if the unit's built-in pool pump timer is used, and not an a separate pool pump timer:

To manually turn the pool pump off for 30 minutes:

Press keypad 1 until the **OFF** light is illuminated.

To increase the manual OFF time:

Select **PUMP OFF** and continue to hold down. After 5 seconds the length of manual off time can be seen in the top right hand side of the unit's screen. This will increase every few seconds.

Release the keypad when the required length of time is reached.

PUMP AUTOMATIC ON and OFF

The following instructions apply if the unit's built-in pool pump timer is used, and not an a separate pool pump timer:

Automatic Readings:

Press and release keypad 1 until **AUTO** is illuminated.

The unit has daily factory pre-set ON and OFF times of:

P1: 8am to 10am

P2: 6pm to 8pm.

P3& P4: Optional – to operate pool pumps more than twice per day

It is a 24-hour clock. For example, 8pm reads as 20.00 hrs.

Pre-set pump times will automatically turn the pool pump ON and OFF.

RE-CALIBRATING CHLORINE

Recalibrating Chlorine(ORP)is **not needed** and it should not be done without the prior advice of Pool Controls.

TO CHANGE THE CLOCK TIME

Press **ENTER**

Select **SETUP** using keypad B

Press **ENTER**

Enter the pin number if **ENABLED**

Select **CLOCK** using keypad B

Press **ENTER**

Select **TIME**

Press **ENTER**

Select **MINUTES** using keypad B

Press **ENTER** to increase the minutes

Select **HOURS** using keypad B

Press **ENTER** to increase the hours

Select **OK** using keypad A

Press **ENTER** to get back to the clock setup

Press **ESCAPE** 3 times to get back to the main menu

TO SET THE DATE

Press **ENTER**

Press **SETUP** using keypad B

Press **ENTER**

Enter the pin number if **ENABLED**

Select **CLOCK** using keypad B

Press **ENTER**

Select **DATE** using keypad B

Press **ENTER** to select the date

Select **DAY** using keypads A or B

Use the **ENTER** keypad to select MON, TUE etc.

Select **MONTH** using keypad A or B

Use the **ENTER** keypad to select the month

Select **YEAR** using keypads A or B

Use the **ENTER** keypad to select the year

Press **ESCAPE** 4 times to get back to the main menu

(If the required date, day, month or year are bypassed, keep pressing the keypad until the required data is shown)

DRILLING TAPPING BAND HOLES

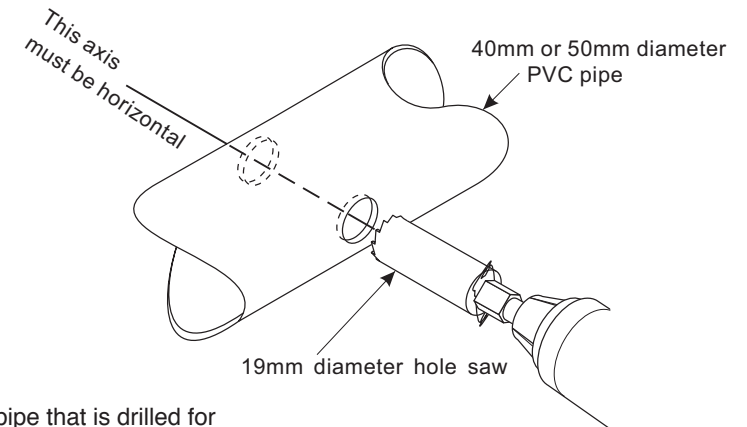

The PVC pipe that is drilled for the Tapping Band must be located on the inlet (suction) side of the pool pump.

TAPPING BAND AND MULTI-ELECTRODE

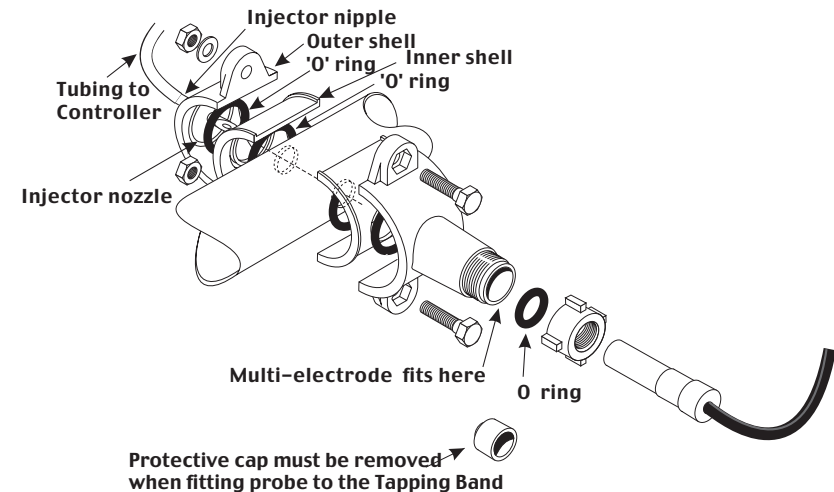

DRILL AND TAP INSTALLATION

PROBE INSTALLATION IN LARGE DIAMETER PIPE

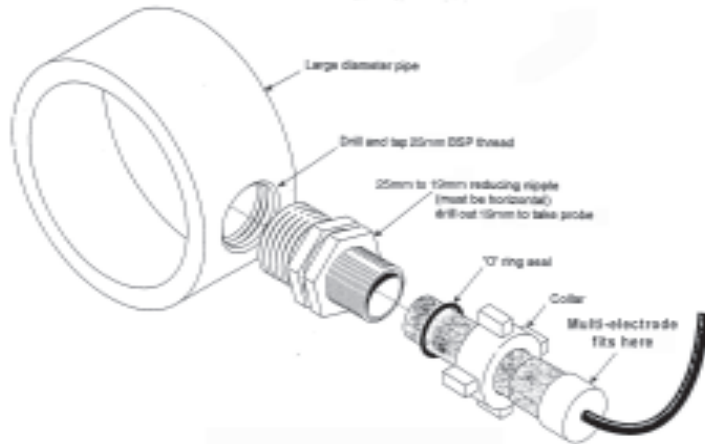

CHEMICAL INJECTION POINT INSTALLATION IN LARGE DIAMETER PIPE

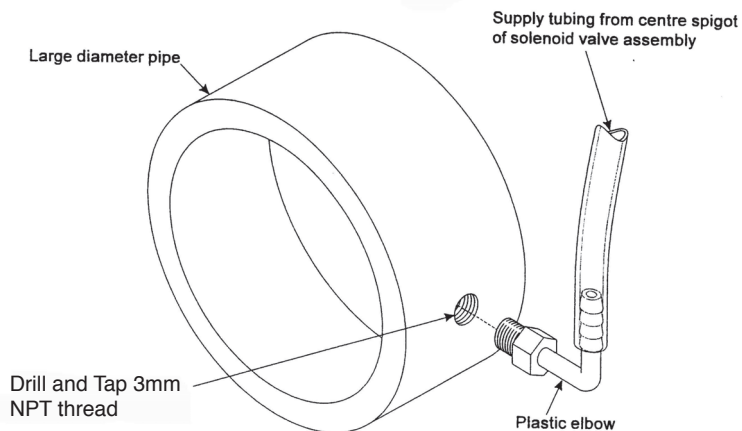

To Turn On the Chlorine

Press and hold down keypads 9 and 0 at the same time for 3 seconds, after which time the unit will beep and resume displaying the set and actual values for the Chlorine (ORP) of the pool.

To Turn Off the Pool Acid (pH)

Press and hold down the keypads 7 and 8 at the same time for 3 seconds. While doing so the display will show “TO DISABLE pH HOLD FOR 3 SEC” and at the end of the 3 seconds it will display “pH OFF”.

To Turn On the Pool Acid (pH)

Press and hold down keypads 7 and 8 at the same time for 3 seconds, after which time the unit will beep and resume displaying the set and actual values for the pH of the pool.

MANUAL DOSING OVERRIDE

If as a result of a pool water test it is determined that the Chlorine and/or pH are not within acceptable levels, the Chemigem can perform a manual dosing operation to rapidly add Chlorine and pool Acid.

Keypads “A” and “B” carry out this function. Normally it will only be necessary to have to dose one of the chemicals in this fashion but if for any reason both of these keypads are pressed at once, only the pH will operate.

As soon as the manual-feed keypad is pressed the main screen will appear blank for 2 seconds after which it will display which feed is taking place. Feeding will continue for about 20 seconds, while the keypad is pressed. When the display panel returns to normal, the dosing stops. Press again to repeat as many times as required. See pages 29&30 for more details.

CALIBRATING THE UNIT

Do not re-calibrate until identical pH readings have been obtained from at least three test kit results from around the pool, or from a Multi-electrode in a Buffer solution.

Press **ENTER** - Use arrow across to **SERVICE**

Press **ENTER** - Enter 4 digit pin number 8934. Use arrow across to **SYSTEM**

Press **ENTER** - Use arrow across to **GLOBAL**

Press **ENTER** - Use arrow across to **CALIBRATE**

Press **ENTER** - Choose **CHLORINE / pH or TEMP** by moving arrow across

If calibrating pH:

Use arrow across to **pH**

Press **ENTER** - use arrow to go to **DECREASE or INCREASE**

Press **ENTER** to change calibration

KEYPAD “B”: “POOL ACID MANUAL FEED”

If as a result of a pool water test it is determined that the Pool Acid (pH) is not within acceptable levels, the Chemigem can perform a manual dosing operation to **lower** the level rapidly.

The unit is equipped with the facility to override its normal operation and to dose pool Acid manually.

Refer also to keypad “A” that manually feeds Chlorine.

Normally it will only be necessary to manually dose either Chlorine or pool Acid, however if for any reason keypads “A” and “B” are both pressed at once, only the pool Acid will operate.

As soon as the manual-feed keypad is pressed the main screen will appear blank for 2 seconds after which it will display which feed is taking place.

Feeding will continue for about 20 seconds, while the keypad is pressed.

EMPTYING SWIMMING POOL AND FREEZING CONDITIONS

- If the pool water is emptied from the swimming pool, pool pump, pool filter and associated pool piping for any reason (such as when the pool is being serviced)
- During periods of freezing conditions (below 32 degrees fahrenheit or zero degrees celsius)

It is essential to remove the Multi-electrode and to cover the sensing end of the Multi-electrode with the white protective cap that is provided (Refer to page 13) and to temporarily seal the resultant exposed hole in the Tapping Band (to avoid water seepage or sand and dirt entering the pool piping).

Failure to carry out these functions may damage the Multi-electrode and negate the Warranty.

Refer to page 13 for the re-installation of the Multi-electrode.

Contact the supplier of the Chemigem or a qualified pool maintenance technician if assistance is required for the removal and re-installation procedures.

TURNING ON AND OFF THE CHLORINE AND POOL ACID

Do not turn off either the Chlorine or pool Acid supply without advice from a qualified pool maintenance technician or the supplier of the Chemigem.

Turning off the supply of either of the chemicals is not normally necessary and could lead to unbalanced pool water that may not be safe for swimming.

In the event that it is necessary to turn off (disable) the Chlorine or pH function, the Chemigem has an easy means of doing this:

To Turn Off the Chlorine

Press and hold down keypads 9 and 0 at the same time for 3 seconds. While doing so the display will show “**TO DISABLE CHLORINE HOLD FOR 3 SEC**” and at the end of the 3 seconds it will display “**CHLORINE OFF**”.

INSTALLATION GUIDE FOR DRILL AND TAP FOR LARGE DIAMETER PIPE

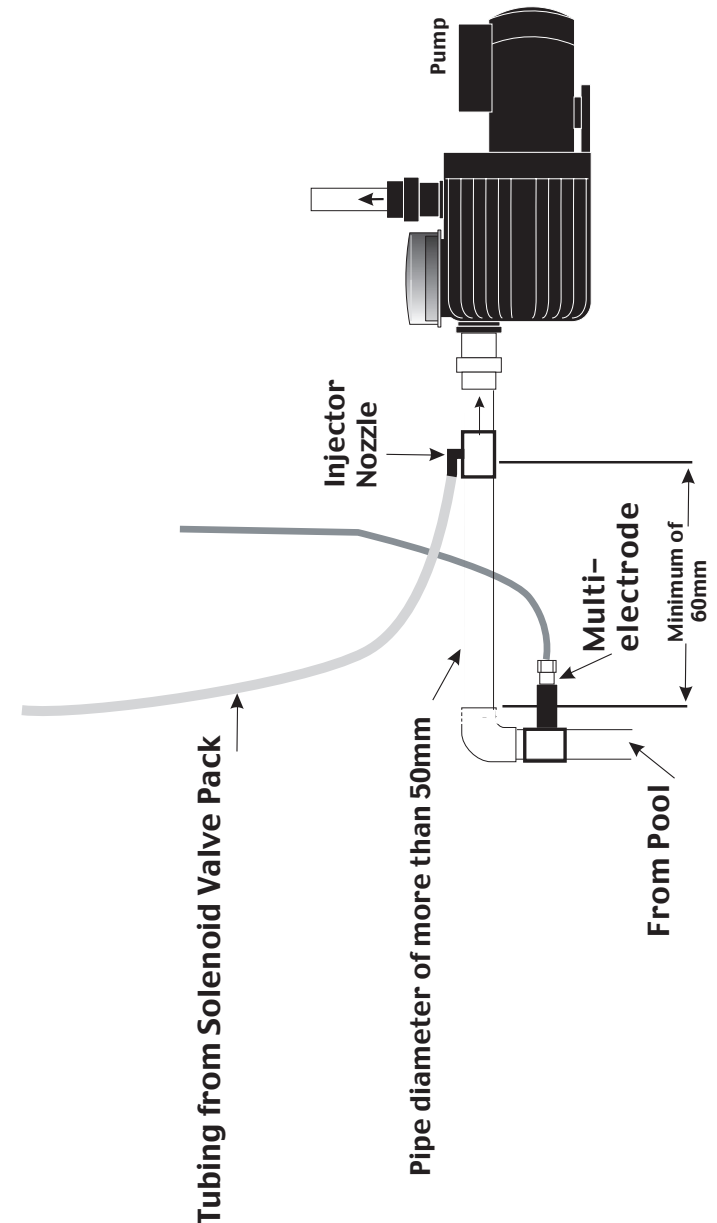

FITTING CHEMIGEM CHEMICAL CONTROLLER BELOW POOL WATER SURFACE LEVEL USING SOLENOIDS

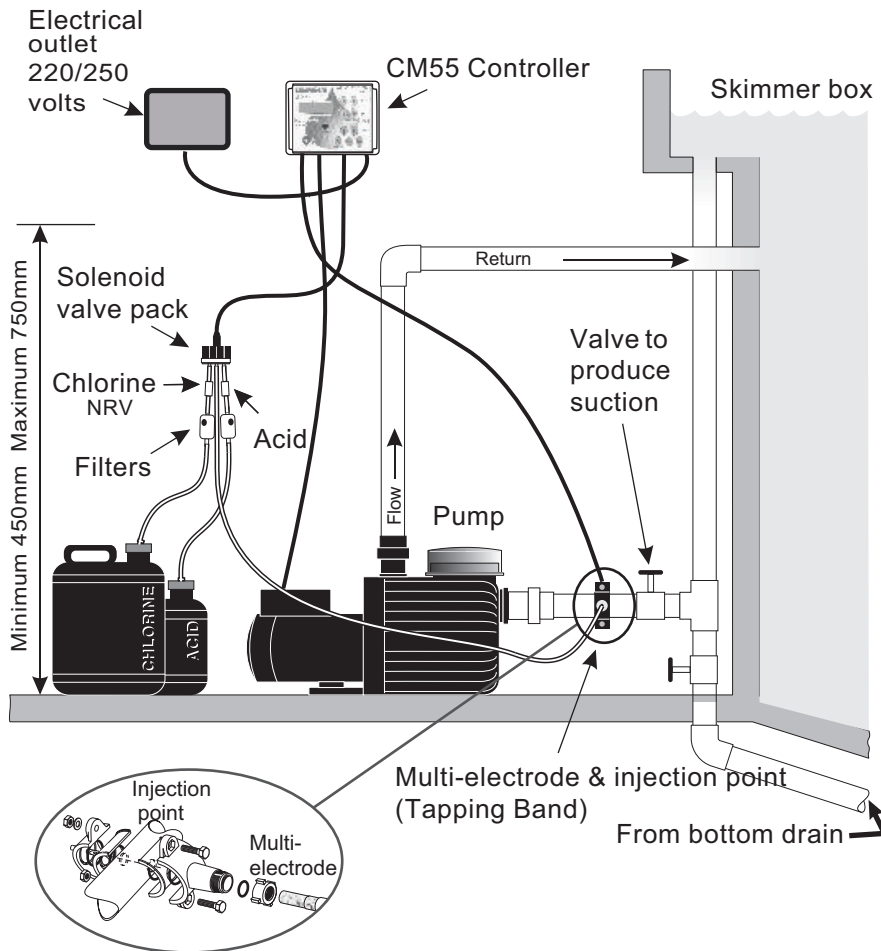

NOTE:

NRV = Non Return Valve

If the pH level required is lowered using keypad 7 the unit will achieve the new level quickly by adding some pool Acid.

However if the pH level required is raised using keypad 8, the unit cannot make the changes rapidly. (If Chlorine is added to the pool water during the next few weeks it will slowly raise the pH of the pool water)

These two keypads are also used together to turn the pH function on and off.

To manually turn off the pH and to turn it on again, refer to page 31

KEYPADS 9 and 0:

“AUTOMATICALLY INCREASE AND DECREASE CHLORINE SET LEVELS”

Keypads 9 and 0 are used to set the level of Chlorine required in the pool water. The keypads raise or lower the required level and the Chemigem will then acquire and hold the set level.

If the Chlorine level required is to be lowered, keypad 9 will lower the set level. It may take some days or even weeks before the Chlorine level drops to the required setting.

However if the Chlorine level is to be raised, press keypad 0. The unit will feed Chlorine every 3 minutes until the set level is reached.

To manually turn off the Chlorine and to turn it on again, refer to page 30

KEYPAD “A”:

“CHLORINE MANUAL FEED”

If as a result of a pool water test it is determined that the Chlorine is not within acceptable levels, the Chemigem can perform a manual dosing operation to bring the level up rapidly.

The unit is equipped with the facility to override its normal operation and to dose Chlorine manually. Keypad “A” performs this function.

Refer also to keypad “B” that manually feeds pool Acid (pH)

Normally it will only be necessary to manually dose either Chlorine or pH, however if for any reason keypads “A” and “B” are both pressed at once, only the pH will operate.

As soon as the manual-feed keypad is pressed the main screen will appear blank for 2 seconds after which it will display which feed is taking place.

Feeding will continue for about 20 seconds, while the keypad is pressed.

When the display panel returns to normal the dosing stops.

Press again to repeat as many times as required.

After manually dosing with Chlorine, monitor the setting for several hours afterwards to make sure that the recommended levels have been restored.

KEYPADS 2 and 3: “AUXILIARY”

To set **ON** and **OFF** times for Auxiliary equipment repeat the steps described for **PUMP** control and timer settings, selecting **AUX**

Examples of Auxiliaries are:

- Pool Light
- Garden lights
- Security lights
- Small fountain pump
- Chemical dosing pumps

KEYPAD 4: “ESCAPE” AND “ALARM MUTE”

The keypad has three functions: -

- When the setup of the Chemigem is completed or required changes made, pressing the **ESC** keypad will return to normal display.
- When alarms are sounding it can be pressed to mute the warning tone. The warning tone will be restored when the unit next switches on. The flashing red light remains on until the pool chemistry returns to the preset levels.

KEYPAD 5: “HELP”

This keypad gives a reminder to check the pool water with a quality test kit.

KEYPAD 6: “ENTER”

The main feature of the keypad is to obtain the menu items and to select those that are made to flash.

- Pressing this keypad brings the “**MAIN MENU**” items on to the screen
- It will select any word that is flashing on the screen. To change the word that is flashing, use keypads A or B, then press keypad No. 6 again to select it.

It also advances the digits when setting the clock and timer

When adjusting times in the “**CLOCK**” or “**TIMER**” functions, each press of the **ENTER** keypad advances the number which is flashing, by one digit. (Refer to pages 32& 33)

KEYPADS 7 and 8: “AUTOMATICALLY INCREASE AND DECREASE POOL ACID SET LEVELS”

Keypads 7 and 8 are used to set the level of pH required in the pool water. The keypads raise or lower the required level and the unit will then acquire and hold the set level.

FITTING CHEMIGEM CHEMICAL CONTROLLER TO A HEATED POOL USING SOLENOIDS

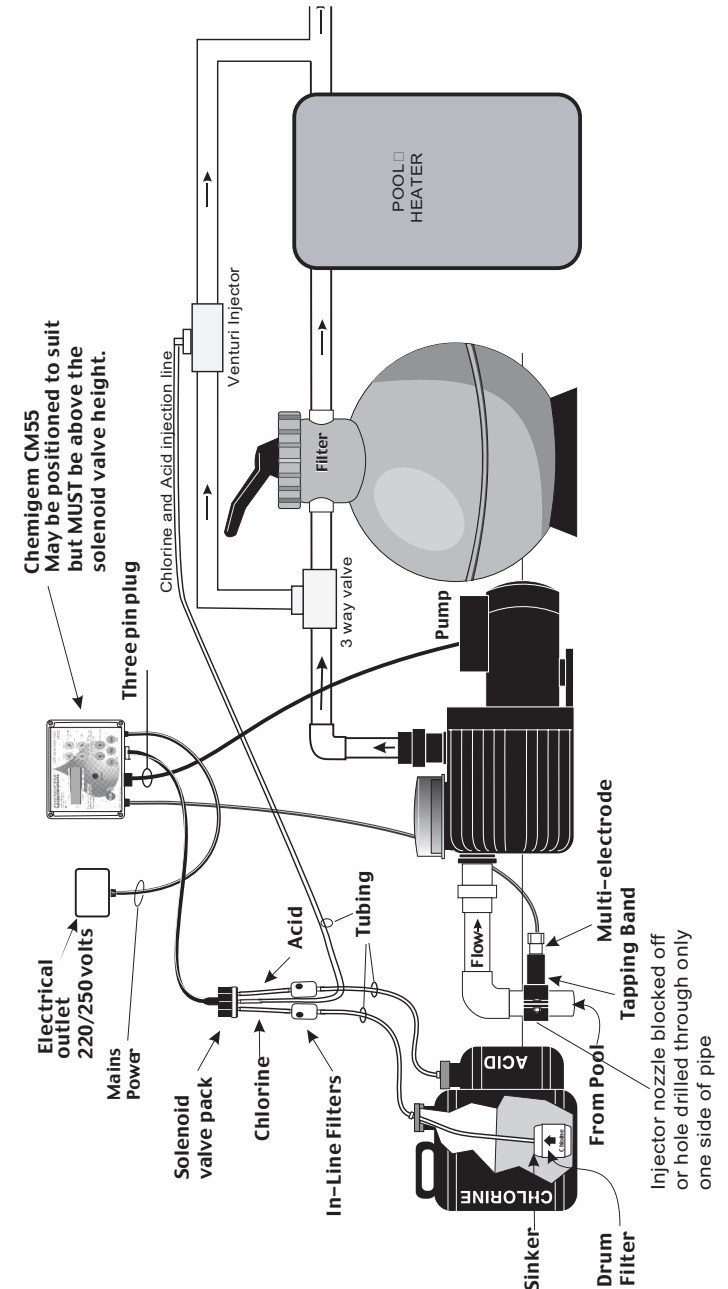

Fitting Multiple Sets of Solenoid Valves to Commercial System

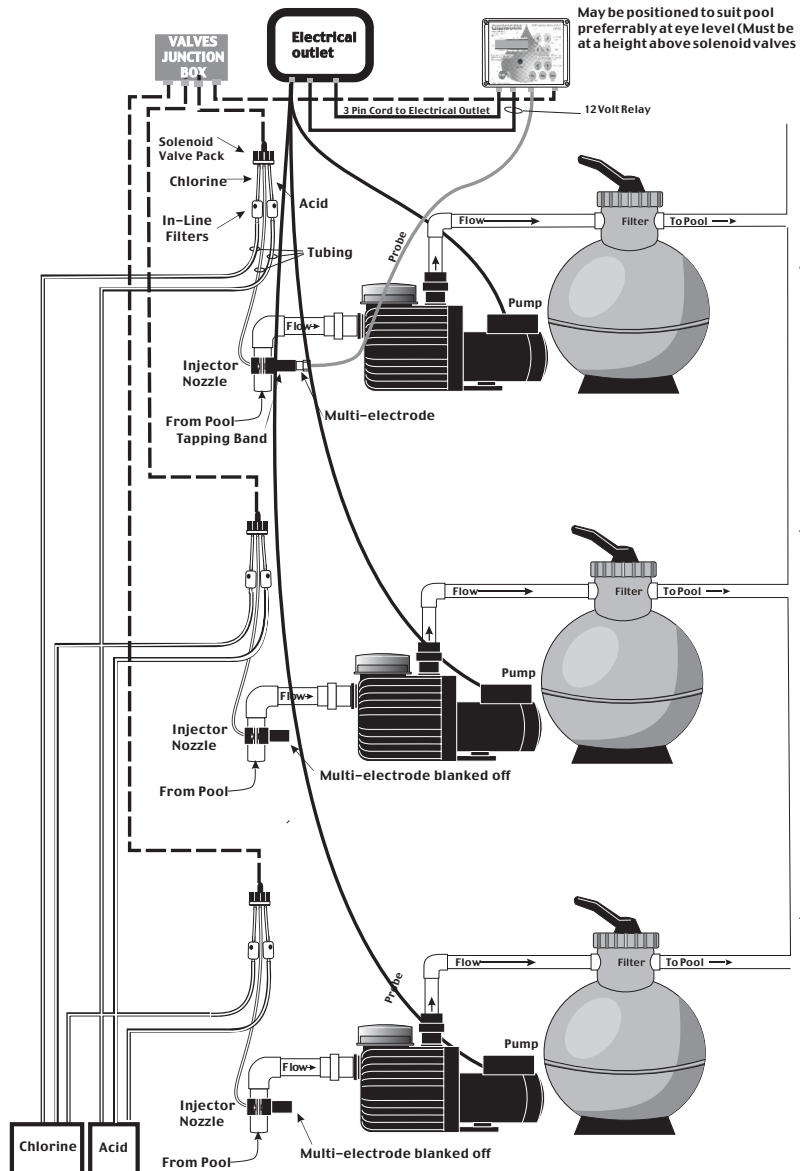

KEYPADS

KEYPAD 1: "PUMP"

When the power has been switched on the screen will light up, however the pool pump will not operate unless the time is within a PUMP-ON period.

This keypad controls the operation of the pool pump and the controlling function of the unit. It has three positions and scrolls through them with each press on the keypad.

- The first press will move the pump status from "AUTO" to "ON" and the pool pump will then run for 30 minutes. The screen will show a message to confirm this
- Pressing the keypad again will move the pump status to "OFF" and the screen will confirm this
- With a third press the pump status will return to "AUTO" and the timer will then switch the pump on and off according to the times set

Dosing of chemicals will only commence after a few minutes to allow for adequate mixing and accurate monitoring. Similarly the safety warning sounds and alarm signals will not operate for the first 4 minutes.

Every 3 minutes Chlorine will feed for 8 seconds and then pool Acid will feed separately for 7 seconds, until the required chemical levels are reached - depending on how the unit has been programmed.

Depending upon how the unit has been programmed, the standard procedure is that the first time that the unit operates it will take approximately 120 minutes to fully adjust to the required levels of Chlorine and pH. Thereafter it will normally restore the required levels in approximately 30 minutes.

Ensure that the pool pump is running for a sufficient period to carry out these adjustments.

Should a manual "ON-TIME" longer than 30 minutes be required, proceed as follows:

- Press "PUMP" keypad 1 a few times until the screen message states that the pump is operating under "AUTOMATIC TIMER"
- Press once more and hold down continuously keypad 1 until the required "ON-TIME" in hours is displayed on the screen

The unit will then operate for that number of hours and when all manually set times have expired the unit will automatically return to "AUTOMATIC TIMER" to switch on and off the pool pump.

If the Chemigem inbuilt pool pump timer is disabled by the pool operator, the unit will lose the ability to turn the pool pump on manually with the "PUMP" keypad. To turn the pool pump on or off manually when the timer has been disabled, use the mains power switch.

To reinstate the inbuilt timer, set "Automatic Pump Times" (Refer to page 34)

levels of Chlorine and pH. Thereafter it will normally restore the required levels in approximately 30 minutes.

Ensure that the pool pump is running for a sufficient period to carry out these adjustments.

If the actual chemical levels being achieved by the unit are not closely matching the “SET” levels, make minor adjustments (either up or down as the circumstances warrant) to the “SET” levels and re-test after 24 hours.

Additions by the unit are made in minutes, but removing excess chemicals may be difficult and require weeks.

Do not go outside the ranges given on page 37 and pay attention to any specific requirements given by the pool builder.

Always take samples at a point near the skimmer box, for this is where the water is completely mixed giving the most accurate readings, **never** near the pool returns (eyeballs) where the water may have been freshly dosed by the unit.

Always follow the specific requirements of the pool builder when setting the chemical levels for the pool.

REGULAR CHECKS ON THE QUALITY OF POOL WATER

As a precautionary measure to ensure that the desired pool water chemical levels are being maintained and that the Chemigem is functioning correctly, regularly check the pool water quality with a good quality test kit.

If the pool is heavily used (such as in hot weather) it must be checked more frequently.

As a general guide it is recommended that the check should be made at least twice weekly in the swimming season and once each two weeks in the non-swimming period.

Seek guidance from your local authority or qualified pool maintenance technician.

REGULAR CHECKS OF THE TUBING

Regularly check the tubing to ensure that it has not become brittle.

If the tubing becomes brittle, it must be replaced immediately.

ELECTRONIC CLOCK

The Chemigem has an in-built electronic clock with a battery back up (which should last for several years) that controls the automatic switching on and off of the pool pump. (Refer to page 32)

DOSING OF CHEMICALS

Dosing of chemicals will commence a few minutes after the pool pump has been switched on to allow for adequate mixing and accurate sensing. Similarly the safety warning sounds and alarm signals will not operate for the first 4 minutes. (Refer to page 27)

TO AVOID THE RISK OF ELECTRIC SHOCK

Replace damaged cord immediately

Do not use extension cord to connect unit to electric supply. Provide a properly located outlet.

OPERATION

INTRODUCTION

The Chemigem Commercial Chemical Controller is designed for use with all types of pools and to measure and automatically assist the Chlorine and pH levels in the pool water.

Once levels are finally set or adjusted, the unit should be left alone.

The unit has been factory-set to achieve 650 millivolts Chlorine (ORP) and 7.7pH as the preferred levels for Chlorine and pH respectively.

It has been found that if ORP is maintained at 650 millivolts, the kill time of E-coli type bacteria is about one second.

If the ORP is lowered to 550 millivolts, the same organisms could take up to 2 hours to be eliminated.

If the unit is used with these factory-set points as the selected levels, it should obtain approximately 2-4 ppm Chlorine and 7.7 pH, providing the stabiliser level is at 50 ppm. If the stabiliser level is 30 ppm or less, the Chlorine will be around 1 ppm.

It is imperative that the unit only operates at the same time as the pool pump. If the unit is left switched on when the water is not circulating, concentrated chemicals may flow into the pool pipes where they can mix and produce poisonous Chlorine gas and also water can flow back into the chemical drums causing them to overflow.

READING THE DISPLAY PANEL

600	> <	SET	650	CHLORINE(ORP)
7.2	> <	SET	7.7	pH

What do the Chlorine and pH Numbers Represent?

- The Chlorine (ORP) number is the activity of the chlorine (see explanation of ORP below and measures in millivolts. (Refer to page39)
- The pH number is the measure of acid / alkalinity and is displayed in units of the pH scale. (Refer to page 38)

What IS ORP?

The Chemigem is designed to measure and automatically adjust Chlorine (ORP) and pH levels in the pool water. (Refer above). As an explanation of what ORP is, the following is provided:

For the past 20 years operators in many parts of the world have used Oxidation-Reduction-Potential (ORP or REDOX) values as a measure of Chlorine activity in water. ORP is a measure of the oxidizing properties of the Chlorine in the water and is easily monitored by the Chemigem Multi-electrode.

When the Multi-electrode is placed into water containing Chlorine it behaves like an electric cell and creates a small but measurable electric voltage. This voltage is proportional to the activity of Chlorine in the water.

It has been found that if ORP is maintained at 650 millivolts, the kill time of E-coli type bacteria is about one second. If the ORP is lowered to 550 millivolts, the same organisms could take up to 2 hours to be eliminated.

The test kit will measure Chlorine as parts per million (ppm) but the activity level of the Chlorine (and therefore the kill-time) depend upon the other materials dissolved in the pool water.

For an ORP controller to work properly the pH, Total Dissolved Solids (TDS), stabiliser (Iso cyanuric acid) and calcium hardness must be maintained within the recommended levels given on page 37

Left Hand Side of Display Screen

The numbers on the left hand side of the display screen are the values the Multi-electrode is registering for the **actual** levels of Chlorine and pH within the pool water.

The Chemigem will work to achieve the same values as those “**SET**” on the right-hand end of the display.

Right Hand Side of Display Screen

The numbers on the right-hand side of the display screen are the values “**SET**”.

The unit has been factory-set to achieve 650 millivolts Chlorine (ORP) and 7.7pH as the preferred levels for Chlorine and pH respectively.

These settings may be raised or lowered using the keypads 7 and 8 for pH and 9 and 0 for Chlorine (ORP) to the right of the display screen.

PASSWORD

The Chemigem is protected by a password if enabled.

The number will be required when operating the function changing keypads.

The screen provides information as to how to select a three-number password. The unit cannot be disabled without the use of the password numbers.

Ensure that the password numbers are retained in a safe location for later reference.

BEFORE STARTING THE CHEMIGEM

Before switching on the Chemigem carry out a full water test with a good quality test kit and balance the pool water to the levels shown below.

If the pool water is not balanced when the unit is first turned on, the unit may fail to correctly control the pool water.

Calcium Hardness, Total Alkalinity and pH should be adjusted first, followed by Chlorine and then Stabiliser (Iso-cyanuric acid).

Initial set up by the pool builder often includes the addition of the first amounts of chemicals. These may be estimated amounts and may require adjustment.

- Adding chemicals will take only a few minutes but removing the chemicals depends upon the natural dissipation from the pool, which could take weeks

- pH is lowered by the addition of acid
- Do not overdose the pool with Chlorine, pool Acid or Stabiliser
- Always add the various pool chemicals slowly and with care, allowing sufficient time for complete dissolving and mixing throughout the pool water
- Finally, carry out careful water tests to determine whether the correct amounts have been added

If unsure how to carry out a water test and/or initially balance the pool water, request a qualified pool maintenance technician to do this for you.

It is suggested that swimming pool water should be maintained within the following ranges and that these ranges are confirmed with your local authorities as meeting their standards:

• CHLORINE	1.0 to 3.0 ppm
• pH	7.2 to 7.8
• CALCIUM HARDNESS	100 to 200 ppm
• STABILISER	30 to 50 ppm
• TOTAL ALKALINITY	80 to 200 ppm
• TOTAL DISSOLVED SOLIDS (TDS)	300 to 2000 ppm

Pay particular attention to the instructions on the chemical drums. Add each chemical separately and slowly allowing plenty of time for them to dissolve. Always test between additions with a good quality test kit.

When diluting chemicals **always** add the concentrated chemical substance to the water and **never** add the water to the concentrated chemical. Some chemicals react violently with water and can splash into the face and eyes. **Always** wear a protective face shield and gloves for such operations.

After the pool water has been correctly balanced and the unit is switched on, it will measure and automatically adjust the Chlorine and pH levels. Chlorine and pool Acid will feed separately for a few seconds approximately every 3 minutes until the required levels are reached - depending on how the unit has been programmed.

THE FIRST TWO WEEKS

The day following the installation of the Chemigem and after the pool pump has been running for 30 minutes, check the level of Chlorine and pH with a good quality test kit. If either of the levels is not exactly at the levels required, alter the settings a little. The unit will bring about the changes to the chemistry of the pool water as the pool pump circulates the water.

During the two weeks after a pool is first filled, the water chemistry will be settling down. It is likely that chemical levels will fluctuate during this time, so keep a check on the pool water with a good quality test kit or obtain confirmation by seeking help from a qualified pool maintenance technician.

It is not uncommon for new concrete pools to use more acid during their first month or two but do not let the pH and Total Alkalinity remain below recommended levels, or the lifetime of the pool surface may be shortened.

Depending upon how the unit has been programmed, the standard procedure is that the first time that the unit operates it will take approximately 120 minutes to fully adjust to the required