

# Chemigem

# D10

## Water Management System

## User Manual



Head Office: 20 Abrams Street Balcatta WA 6021

Sales/Service Ph: 1300 550 010

Web: [www.poolcontrols.com.au](http://www.poolcontrols.com.au)

Emails:

[sales@poolcontrols.com.au](mailto:sales@poolcontrols.com.au) [service@poolcontrols.com.au](mailto:service@poolcontrols.com.au)

# Contents

<b>Manufacturers' Warranty</b>	<b>1</b>
<b>Introducing the Chemigem D10</b>	<b>3</b>
<b>How it Works</b>	<b>4</b>
<b>Initial Pool Balance</b>	<b>5</b>
<b>Basic Requirements – the Pool Owner</b>	<b>6</b>
<b>Installation Guide &amp; Diagrams</b>	<b>6</b>
<b>Front Panel</b>	<b>12</b>
<b>Navigating the Menu System</b>	<b>13</b>
<b>Timer Menu</b>	<b>14</b>
<b>ORP Menu</b>	<b>16</b>
<b>pH Menu</b>	<b>17</b>
<b>Status Indicator, Warnings and Safety Shutdowns</b>	<b>19</b>
<b>Maintenance</b>	<b>21</b>
<b>Troubleshooting</b>	<b>21</b>

## **IMPORTANT**

***If the power cord is damaged the unit must be returned to Pool Controls for repair.***

***Always read the instructions and warnings on chemical containers before using chemicals.***

**Serial Number.....**

**Date of Installation.....**

**Installed by.....**



# Manufacturer's Warranty

## **Pool Controls Manufacturer's Warranty**

Pool Controls products come with guarantees that cannot be excluded under the Australian Consumer Law. You are entitled to a replacement or refund for a major failure and for compensation for any other loss or damage. You are also entitled to have the goods repaired or replaced if the goods fail to be of acceptable quality and the failure does not amount to a major failure. The benefits under this warranty are in addition to other rights and remedies under a law in relation to the goods.

## **3 Year Warranty on New Domestic Installations**

Pool Controls warrants all its products used in new domestic installations to be free from defects in material and/or workmanship for a period of 3 years from the original date of purchase or installation.

## **2 Year Warranty on Replacement Parts**

Pool Controls warrants replacement parts used in domestic installations, including multi-electrodes (probes), solenoid valves and electrolytic cells (but excluding wearing parts such as tubing and squeeze tubing) to be free from defects in material and/or workmanship for a period of 2 years following purchase.

## **Exclusion for Wearing Parts**

This warranty does not extend to wearing parts, in particular the squeeze tubes fitted in dosing pumps. Squeeze tubes should be replaced every **six months** by a suitably qualified technician. Pool Controls is not liable for any failure of its products or other damage caused by failure of a squeeze tube that has been used for more than six months.

## **WARRANTY OBLIGATIONS OF POOL CONTROLS**

If a defect in workmanship or materials in any Pool Controls product covered by this warranty is discovered during the term of the warranty, and provided the warranty holder follows the procedure set out below, Pool Controls will repair or replace **that item** at the option of the warranty holder.

## **PROCEDURE FOR CLAIMING UNDER THIS WARRANTY**

In order to claim under this warranty, the warranty holder must:

- Contact Pool Controls Service as soon as possible after the discovery of the defect and in any event, within the relevant warranty period;
- Confirm date of installation;
- Confirm that the installation was completed by a suitably qualified technician, as set out in the installation manual; and
- If required, arrange for the relevant Pool Controls' product to be returned to Pool Controls for repair, and the warranty holder is responsible for the cost and risk of any freight or transportation to and from Pool Controls.

## **CALL OUT FEES**

- This is a “Back to Base” Warranty, which means that if the Pool Controls product needs to be serviced, replaced or repaired at a place other than Pool Controls’ premises, a call out fee will be charged to cover the cost of travel by an authorised Pool Controls technician. Please note that this call out fee will NOT be charged when the relevant Pool Controls product is returned to Pool Controls for repair.
- If an authorised Pool Controls technician repairs or replaces a Pool Controls Product and this warranty does NOT apply, a fee for labour and parts supplied will be charged in addition to the call out fee.
- If the Pool Controls product needs to be returned for repairs under this warranty, the warranty holder is responsible for the cost and risk of any freight or transportation to and from Pool Controls.

## **WARRANTY EXCLUSIONS**

- This warranty is for domestic installations only. Where Pool Controls products are installed for a commercial application this warranty does not apply.
- This warranty extends to the original owner only, beginning on the date of installation and is not enforceable by any other party without the prior written consent of Pool Controls.
- Pool Controls is not responsible for any cost of freight or transportation to or from its Service Department.
- Pool Controls is not liable under this warranty if the installation of the Pool Controls product was not carried out by a suitably qualified technician.
- To the extent permitted by law, Pool Controls is not liable for:
  - any incidental or consequential loss incurred in connection with the removal or replacement of the Pool Controls product under this warranty; or
  - product failure resulting from misuse, freezing, accident, negligence, improper installation or inadequate maintenance.
- To the extent permitted by law, Pool Controls disclaims all other warranties, either express or implied, including, but not limited to, implied warranties of merchantability and fitness for a particular purpose with regard to Pool Controls products, parts and/or any accompanying written materials.

## **REGISTER YOUR WARRANTY NOW**

Go to [www.poolcontrols.com.au](http://www.poolcontrols.com.au), click on the warranty registration tab to fill in your details.

## **CONTACT POOL CONTROLS**

Pool Controls is based at 20 Abrams Street, Balcatta, Western Australia. We also have service technicians based in NSW, Queensland and Victoria.

- Service Email: [service@poolcontrols.com.au](mailto:service@poolcontrols.com.au)
- Service Phone: 1300 550 010

## What's in the box?

- Multi-electrode (probe)
- D10 Controller and Mains Cable
- Tubing
- Dose Pump Module or Valve Module
- User Manual
- Injection manifold
- Mounting hardware (raw plugs, screws and paper template)

## Operation Following a Power Failure

The D10 unit comes with a timer function built into the operating software. The timer is a 24-hour type with quartz-crystal control. This Timer is backed-up by a Real-Time Clock (RTC) similar to those found in computers.

During a power failure the D10 will keep time and maintain AutoMode functions.

If a Filter Cycle is active when power is returned the pump will be turned ON within 1 minute. The D10 will keep all its settings and will not need to be re-programmed.

The D10 is ideal for use in systems where repeated power cuts occur, such as off-peak power circuits and Queensland's Tarriff33 system.

## How it works:

The D10 continuously analyses pool water chemistry while your pool system is running. The base model has two dosing pumps that dose liquid chlorine and acid to the pool water flow in response to the water analysis from the probe.

The D10 can also be used to control a Salt Water Chlorinator with and without extra available dosing from the chlorine dosing pump. The chlorine dosing pump is always available for manual dosing.

**Note: the filter system should always be running when the pool is being used.**

### Oxidation Reduction Potential

The D10 measures how much chlorine is in pool water by measuring the ORP of the water.

ORP stands for Oxidation Reduction Potential. Chemicals like chlorine destroy pathogens (eg harmful bacteria) in water by oxidising them.

The level of oxidation available in the water can be measured chemically with an ORP sensor contained in the Chemigem multielectrode (probe). This produces a voltage related to the ORP of the water, which is a measure of the effectiveness of chlorine in the water.

Varying the ORP will affect how long it takes to destroy harmful bacteria in pool water. For example, if ORP is maintained at 650mV, E-coli type bacteria will be destroyed in around one second. However, if the ORP is lowered to 550mV, the same organisms may take up to 2 hours to be eliminated.

### pH Control

When chlorine is added to water the pH always changes – this is because chlorine is not a neutral chemical. The pH will slowly rise as chlorine is added to the water. A rise in pH greatly reduces the effectiveness of the chlorine as a sanitiser, so it is important to ensure that the pH remains in the correct range.

The pH of the water can be lowered by the addition of acid – and your D10 does this automatically. The D10 multielectrode (probe) measures the pH of the water and doses the pool with small amounts of acid to keep the pH in the correct range.

## Initial pool balance

Before you begin using the D10 make sure your pool water is balanced as follows:

### Chlorine

If it is a new installation, add enough chlorine (liquid or granular) to achieve a reading of 3ppm on an appropriate test kit.

### Stabiliser

If the pool is outdoors, it is vital that stabiliser (also known as cyanurate and cyanuric acid) be added and maintained at 40ppm to 60ppm. This compound reduces chlorine destruction due to sunlight. However, too much stabiliser will reduce the effectiveness of chlorine and can result in poor quality water so ensure stabiliser does not exceed 80ppm.

***Good stabiliser level keeps good chlorine levels and reduces maintenance.***

### pH

For chlorine to be effective, the pH must be within a certain range. This is usually between 6.8 (fibreglass/liner pools) or 7.2 (concrete/plaster) and 7.8.

Adjust pH down with acid – powder, liquid sulphuric or liquid hydrochloric. Be very careful with acid as it can be harmful and corrosive.

### Total Alkalinity (TA)

Total alkalinity is also known as carbonate hardness or TA for short. The recommended level is between 80 and 120ppm.

TA is related to pH in that it stops the pH from varying quickly with small additions of acidic or alkaline chemicals. When the TA is low it is almost impossible to control the pH.

To raise the TA, buffer (sodium bicarbonate) is added. This must be done slowly as buffer will also cause the pH to rise. As an approximate rule every increase of 20ppm of TA will also cause a 0.1 rise in pH. Once buffer is added it should be left to mix in the pool for a few hours before reducing the pH.

### Phosphates and Nitrates

Phosphate and ammonia nitrogen will make your garden green – and they will do the same thing to your pool. Check for phosphates and add phosphate remover if necessary. Don't let fertiliser get into your pool! Phosphates are also in some cleaning products – check the label if using around your pool.

### When Controlling a Salt Water Chlorinator

Follow the directions for the initial balance for your SWC unit – the difference is likely to only be the addition of salt or minerals. Note that the D10 unit will turn the power to the SWC unit on and off – the SWC unit must be capable of functioning in this manner and should be set to manual operation only (not automatic).

## Basic Requirements – the Pool Owner

Your Chemigem® maintains pool water biological safety by controlling the pH and the ORP (sanitation level). It achieves this by dosing the necessary chemicals into the pool in a controlled manner. The chemical drums must be checked on a regular basis – empty drums will lead to poor balance and incorrect operation.

To achieve water safety effectively and efficiently there are other water balance factors that must be maintained by the pool owner.

The most important water balance factors are described on the previous page.

Failure to maintain these aspects of pool water balance can lead to poor water quality and incorrect/unusual operation of the Chemigem® unit.

In the case of incorrect or unusual operation the pool water must be tested and any balance problems corrected. After this is done it may also be necessary to clean the Probe – this is part of the unit maintenance, see page 21.

### IMPORTANT SAFETY MEASURES:

- Always add concentrated chemicals to water – not the other way around!
- Don't allow chemicals to mix – dangerous, highly corrosive fumes will be produced.
- Always wear protective clothing, footwear, gloves and eye protection when handling pool chemicals to avoid injury.
- If a spill occurs, wash the affected area with fresh water immediately and seek medical attention.
- Work in a well ventilated area and avoid inhalation of fumes.
- Read and follow safety instructions on chemical drums.

## Installation Guide

Installation varies slightly depending on whether you have a solenoid valve model Chemigem® D10 or a dosing pump model. The different methods of installation are described below, and illustrated on page 7 (Solenoid valve model) and page 8 (dosing pump model).

### Choosing a good location

The D10 is manufactured from weather resistant materials and is designed for operation in full sun and rain. However, your D10 will benefit if it is protected from the weather. The D10 Power Supply should not be mounted close to where chemicals are stored (eg acid and chlorine) as vapours from these chemicals are corrosive and may damage the electronic controls within the unit.

Insect intrusion (particularly ants) can cause problems with all equipment. Ensure that the pool equipment area is kept free of insects as much as possible. Insect intrusion is not covered under the warranty.



# INSTALLATION DIAGRAM - VALVE MODULE

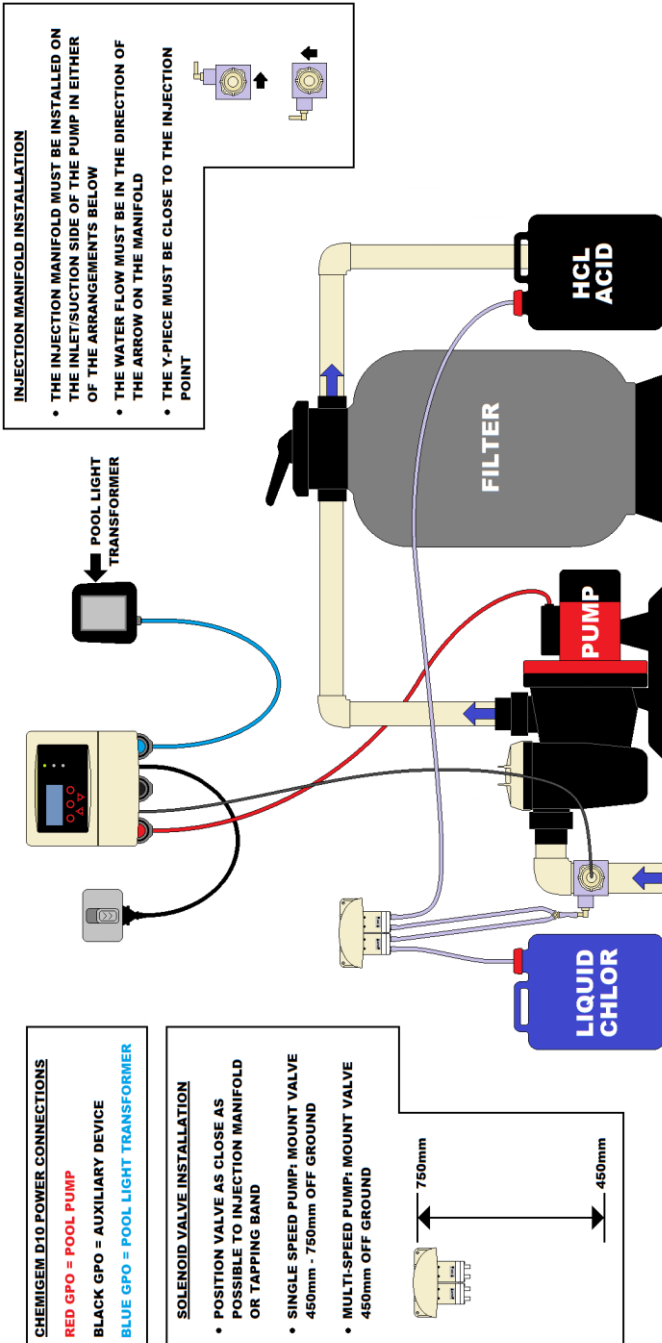

# INSTALLATION DIAGRAM - DOSING PUMP MODULE

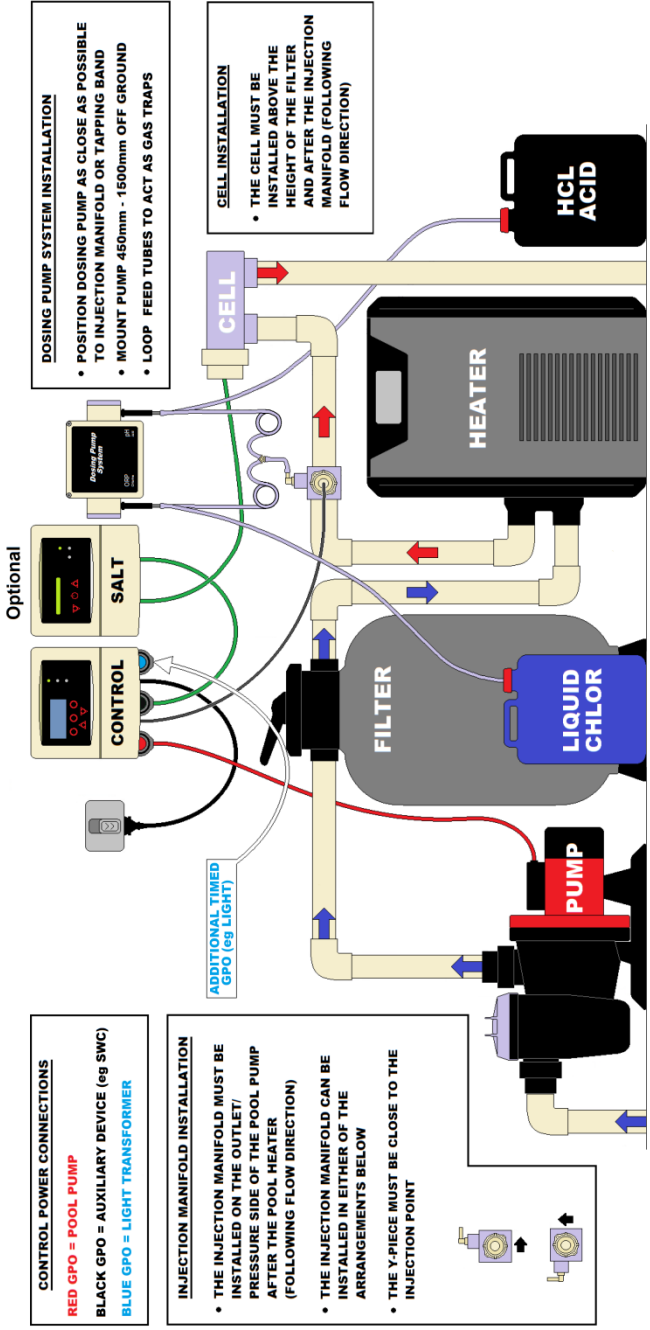

## Installing the D10 Controller

Locate the D10 Controller close to the filtration pump so that it may be connected easily. Connect the D10 Controller to the mains power outlet of the pool area and make sure this outlet meets all applicable Australian Standard at the time of installation.

Mount the D10 Controller at least 1.5m above the ground and at least 3m from the pool water. A mounting template has been provided (last page of manual) with the D10 that shows you where to place screws on either a wall or post.

The PUMP socket outlet in the base of the D10 Power Supply is dedicated to the filtration pump only. Do not use a double adaptor to connect another pump as this will overload the system and void warranty.

Your D10 has two other power outlets on its base, which can be used to run lighting or an SWC unit (or other pool equipment). These outlets are also timed, so accessories can be set to turn on and off automatically.

## Installing the Injection Manifold – keep the Y-piece close to the manifold

Ensure that the suction line has no air leaks. The pump suction must be between -20kPa and -70kPa. Turn off the pool pump before installing the injection manifold.

For **solenoid valve models**, the injection manifold must be installed on the inlet (suction) side of the pump and should be positioned as close to the pump as practicable. It can be plumbed in vertically or horizontally. Ensure that the water flow is in the correct direction (as marked on the injection manifold. For **dosing pump models**, the injection manifold should be installed on the return (pressure) side of the pump, after any accessories such as heaters. **Make sure the Y-piece is installed close to the manifold and that gas loops (for Pump Module) are vertical as this will trap any gas from chemical mixing.**

## Installing the Probe into the Injection Manifold

The probe has a bayonet fitting. To install the probe, simply insert it into the injection manifold and twist to lock the bayonet fitting. Ensure that the o-ring seal is not twisted or out of place.

## Installing a Tapping Band

The solenoid valve model D10 may be installed with a tapping band instead of an injection manifold. This may be useful in certain applications where several pool accessories are to be installed and space is tight.

Ensure that the suction line has no air leaks. The pump suction must be between -20kPa and -70kPa. Turn off the pool pump before installing the tapping band.

The tapping band must be installed on the inlet (suction) side of the pump and should be positioned as close to the pump as practicable.

The tapping band can be installed on either horizontal or vertical pipes, provided that the probe is fitted horizontally. The tapping band has an inner shell for use with 40mm PVC pipes. The inner shell should be removed if the tapping band is to be installed on 50mm PVC pipes.

Drill a 19mm hole through both sides of the PVC pipe. Ensure that the surround to the hole where the O-ring will sit is smooth and clean. Do not use grease or sealant on this fitting. Check that the O-rings are in position and that the arrow on the tapping band is pointing towards the pump.

Fit the tapping band and tighten the nuts by hand, with a final half turn with a wrench. Do not over-tighten.

### **Installing the Probe (with tapping band)**

Remove the protective cap from the probe. Retain cap for possible future use – you will need the cap if you have to empty your pool for any reason, or if your pool is exposed to freezing conditions.

Place an O-ring on to the probe and insert the probe into the probe arm of the tapping band. Turn the probe clockwise by hand to tighten. Do not use grease or sealant on this connection.

### **Chemical drums**

Position the chemical drums in a safe and secure location, preferably about 2 metres from the D10. Ensure you have the right chemicals for your pool and that chemicals have been diluted if necessary (See page 6 for safe chemical handling).

**Make sure that the correct pump/valve is connected to the correct chemical drum!**

### **Installing the Dose Pumps – Outlet Side**

Mount the dose pumps unit adjacent to the D10 Power Supply, as it is hard-wired to this power supply.

The injection manifold comes with a Y-piece and gas loops already installed.

Cut lengths of tubing that will reach from the base of each dose pump to the injection manifold tubing. Connect one end of the tubing to the outlet side of the dose pump (the direction of flow is indicated by an arrow on the front cover of the pump.) Connect the other end of the tube to one of the loops near the injection manifold. **Make sure the gas loops are vertical as this will trap any gas from chemical mixing.**

Cut another length of tubing that will reach from the base of the dose pump to the base of the acid drum. Position the acid drum in a safe and secure location, preferably about 2 metres from the D10.

Connect the one end of this tube to the inlet side of the dose pump (the direction of flow is indicated by an arrow on the front cover of each dose pump.)

Drill an 8mm hole in the lids of the chemical drums and pass the tubing through the hole in the drum lid. Place a sinker on to the end of the tubing that will be in the drum and then attach the drum filter. Note that the drum filter incorporates a non-return valve to prevent back-flow into the chemical drum.

Before placing the tubing into the drum, measure the tubing against the outside of each drum and wrap several turns of PVC tape around the tubing above the drum lid so that the drum filter will be 10-15mm above the bottom of the drum. Lower the drum filter and sinker into the drum and screw on the lid.

### **Installing Solenoid Valves – Outlet Side**

The solenoid valves should be fitted as close as possible to the injection manifold or tapping band. The Y-piece should already be close to the manifold. The valves must be attached to a vertical surface above the top of the chemical drums but no more than 750mm above the base of the drums.

Note: if you are installing a D10 below the pool water surface level and/or if the pool is heated, a dosing pump model is more suitable. Valve models may require isolation valves and/or venturi systems to be fitted to maintain adequate suction pressure.

Ensure tubing is clean and free from dirt or sand before fitting.

Each valve is marked by a label with the outlet being the down arrow. For dual-valves the outlets are the inner spigots. Connect one end of a length of tube/s to the outlet/s and connect the other end to the injection point or the y-piece.

### **Installing the Suction Tubing to the Chemical drums – Pumps and Valves**

Cut lengths of tubing that will reach from the base of the valves or dose pumps to the base of the chemical drum. Make sure the chemical drums are in a safe and secure location, preferably about 2 metres from the D10.

Connect one end of a tube to the inlet side of the valve or dose pump (the direction of flow is indicated by an arrow on a label or the front cover of each dose pump.)

Drill an 8mm hole in the lids of the chemical drums and pass the tubing through the hole in the drum lid. Place a sinker on to the end of the tubing that will be in the drum and then attach the drum filter. Note that the drum filter incorporates a non-return valve to prevent back-flow into the chemical drum. **Connect the correct pump/valve to the correct chemical drum.**

Before placing the tubing into the drum, measure the tubing against the outside of each drum and wrap several turns of PVC tape around the tubing above the drum lid so that the drum filter will be 10-15mm above the bottom of the drum. Lower the drum filter and sinker into the drum and screw on the lid.

## The Chemigem Front Panel: D10 Operational Buttons

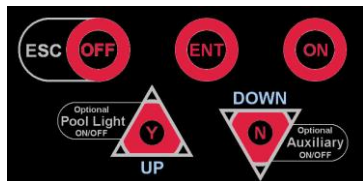

The D10 has 5 buttons that allow you to control its functions. Each button is labelled with its primary function. Secondary functions are labelled within an outline next to the button. Buttons are backlit to show activity, with the ESC/OFF button always available to take you back to the home screen.

### ON Button

#### Turn the System On Manually

Press the ON button once to switch the D10 and the pool pump on manually. The D10 will default back to AUTO and turn itself off automatically at the end of the next programmed FILTER CYCLE (and this time will be displayed on the LCD).

#### Increasing Manual Run-time in Hourly Increments

Press the ON button repeatedly (or hold the button down) to increase the manual run time in hourly increments. The run time is displayed on the LCD. When the desired run time has been reached, press the ENT button to confirm your selection and the system will commence operation.

### ESC/OFF Button

#### Turn the System Off Manually

If the D10 and pool pump are running, pressing this button will turn them off manually. The D10 will automatically turn on again at the start of the next FILTER CYCLE (and this will be displayed on the LCD).

#### Return to Home Screen

If you have unintentionally accessed a D10 Menu that you don't actually require, pressing the ESC/OFF button allows you to return to the home screen at any time.

### ENT Button

Use this button to enter the D10 Menu system and to access the various options in each Menu. Use the Y/UP and N/DOWN buttons to scroll through menu options and when your desired menu option is displayed on the LCD, press ENT to access that option.

### Y/UP Button and Optional Pool Light

If you have accessed the D10 Menu by pressing the ENT button, press the Y/UP button to scroll upwards through the various menu options. Some menu options will prompt a yes or no answer. If you wish to answer "yes", press the Y/UP button.

If your D10 also controls your pool lighting (optional), you can turn the lights on or off manually by pressing the Y/UP button. For multi-coloured lights, hold the Y/UP button down to cycle through the various colours and release once the desired colour is reached.

# The D10 Display

## LCD Display

Line 1	15:27	NORMAL	Auto
Line 2	AutoON → AutoOFF@ 21:00		
Line 3	ORP=670mV	SET=650mV	
Line 4	pH= 7.5	SET= 7.6	

READ OPERATION MANUAL FOR DETAILED INSTRUCTIONS

The D10 uses a four line LCD display to provide the user with information.

- Line 1 shows the current time and the mode of operation. In the example above, line 1, tells you that the time is 3:27pm and the D10 is operating in “Normal Automatic mode”  
Note that the D10 displays the time using a 24 hour clock.
- Line 2 shows timer information. In the example above, line 2 tells you that the “unit is turned ON and will turn OFF automatically at 21:00 (9pm)”
- Line 3 displays ORP (Chlorine) information. In the example above, line 3 tells you that the current ORP is 670mV with the unit set to provide 650mV
- Line 4 displays pH information. In the example above, line 4 tells you that the current pH is 7.5 with the unit set to provide 7.6.

## Navigating the D10 Menu System

There are three aspects to the general D10 Menu system – the Timer Menu, the ORP (Chlorine) Menu and the pH Menu. Access the D10 Menu system by pressing the ENT button and following the prompts on the LCD. If you find you have ended up in a part of the Menu system unintentionally, you can return to the Home Screen by pressing the ESC/OFF button at any time.

Use the Y/UP and N/DOWN buttons to scroll through the various menu options until the desired option is displayed on the LCD. Use the ENT button to confirm that you wish to select that option.

Once accessed, use the Y/UP and N/DOWN buttons to adjust operational settings up or down – and confirm adjustments by pressing ENT. To cancel any adjustments, simply press ESC/OFF to return to the Home Screen.

## Advanced Settings Menu

If you are interested in learning more about additional functionality of your Chemigem<sup>®</sup>, a detailed **Advanced Settings Manual** is available to download from the Pool Controls website - [www.poolcontrols.com.au](http://www.poolcontrols.com.au) or call Pool Controls Service on **1300 550 010** for further information. Some menus in Advanced Settings are:

- POOL – information on pool volume and whether it is concrete or fibreglass
- SYSTEM DATA - shows service information
- FILTER CYCLES - 4 Filter Cycles can be active - useful for seasonal adjustment.
- AUX - controls timed operation of auxiliary power outlet
- FULL MANUAL ON or AUTO TIMER ON – use when the D10 is being run as a “slave” to another controller.

## Timer Menu

### Setting the time

Once you have installed your D10 and turned it on, you will need to set the correct time on the Chemigem 24 hour clock.

First, access the Menu System by pressing the ENT button.

The LCD will display the word TIMER MENU. Select this by pressing the ENT button once more.

Line 2 on the LCD will now read SET TIME HOURS. Press ENT to select this option and then use the Y/UP and N/DOWN buttons- to adjust the hours on the LCD. Confirm the correct hours value by pressing ENT again.

The LCD will now show SET TIME MINUTES. Adjust the minutes using the Y/UP and N/DOWN buttons. When complete, press ENT to return to normal operation.

## ADJUST CYCLES Sub-Menu

Your D10 has two filter cycles pre-programmed as factory defaults as follows:

Filter Cycle 1:	ON at 07:00 (7am)	OFF at 10:00 (10am)
Filter Cycle 2:	ON at 18:00 (6pm)	OFF at 21:00 (9pm)

You can change the start and finish times of each filter cycle to meet your sanitiser requirements and to suit your lifestyle.

To adjust filter cycle start and finish times, press ENT to access the D10 Menu system. Press ENT again to select the TIMER menu and then scroll down using the N/DOWN button until ADJUST CYCLES is displayed on the LCD.

Select this option by pressing ENT and the LCD will show the start (ON) time of the filter cycle being adjusted. Use the Y/UP and N/DOWN buttons to adjust the start time. Press ENT to confirm your selection and then the LCD will show the end (OFF) time for that filter cycle. Adjust the OFF time in the same way as the ON time and press ENT to confirm.

After ON and OFF times for the first filter cycle have been adjusted, the ON time for the second filter cycle is shown on the LCD. This can be adjusted in the same way, or if you do not wish to make any changes, simply press ENT to confirm the time shown on the LCD. Follow the same process to either adjust or confirm the OFF time for the second filter cycle, and once this has been confirmed the LCD will display the home screen.

Note: an additional 2 filter cycles can be enabled and programmed via the Advanced Settings Menu. For details on how to access this menu, please refer to the Advanced Settings Manual (available to download from [www.poolcontrols.com.au](http://www.poolcontrols.com.au)) or call Pool Controls Service on 1300 550 010.



## Running Times

We recommend your system be operated for ***at least 4 hours per day and always run the system when using the pool.***

As sunlight destroys chlorine, it is recommended that the D10 be run mostly in the evening.

Chlorine is added for sanitation but the filter is needed to remove pollutant particles (dust, sand etc) and keep the water looking good. The filter must operate for a reasonable number of hours per day to remove pollutants. If there are adverse local conditions – such as windborne dust and debris - the chlorine demand will be higher than normal and you will likely need to operate the system for longer periods to adequately filter the water.

## Optional LIGHT Timer Sub-Menu

You can use your D10 to turn your pool or garden lighting on and off automatically, you can set the ON and OFF times using the light timer menu.

Press ENT to access the D10 Menu system. Press ENT again to select the TIMER menu and then scroll down using the N/DOWN button until LIGHT MENU is displayed on the LCD.

Line 2 on the LCD will now read “AUTO? Y/N”. To enable automatic light operation press the Y/UP-button. Line2 will read “Auto ON” for short period before displaying “ON hh:mm”.

Adjust the ON time using the Y/UP and N/DOWN-buttons and confirm by pressing ENT. The LCD will now prompt you to set the OFF-time, which is accomplished using the Y/UP and N/DOWN-buttons as before. Press ENT-to confirm the new OFF-time and the LCD will return to the home screen.

To disable automatic light operation, access the LIGHT menu in the way described above and when asked “AUTO? Y/N” - press the N/DOWN button. Line 2 will read “Auto OFF” for short period then the system will return to normal operation and the light can only be operated manually (see below for how to do this).

## Manual Light Operation

If the D10 is turned on, the light can be turned on or off manually by pressing the Y/UP-button.

If you have multi-coloured LED lights that cycle through different colours and requiring a power pulse to change effects, you can hold down the Y/UP-button to cycle through the options and release when the desired colour or effect is achieved.

## ORP (Chlorine Menu)

### Accessing the ORP Menu

Access the Chemigem Menu System by pressing ENT. Use the Y/UP or N/DOWN button to scroll through the main menu until ORP MENU is displayed on the LCD. Press ENT to select.

### Manual Feed

Having accessed the ORP menu, the LCD will ask “Manual Feed Y/N?”. Press Y/UP to select and (on solenoid valve models) the display will read “FEED 5 Sec/50mL”. On dosing pump models the display will read “FEED 5 mins/75mL”

You can increase the amount of the dose by pressing the Y/UP button until the desired dose amount is displayed. (Note: the dose volume displayed is an estimate only)

Press ENT and (depending on which model you have) either the solenoid valve or the dose pump will commence feeding liquid chlorine.

### Superchlorination (Solenoid Valve Models Only)

When bathers enter a pool there is a reaction between nitrogen/ammonia compounds from the bathers and the chlorine. These reactions form chloramines (also called combined chlorine) which are responsible for the “chlorine” odour and for some minor irritations.

These compounds can be broken down by adding chlorine to a level above 5ppm by the addition of a shock dose – also known as superchlorination. If you have a solenoid valve model, your D10 can superchlorinate you pool automatically via the SUPER CHLOR sub-menu. (the SUPER CHLOR function is not available on dosing pump models)

To access the SUPER CHLOR sub-menu, enter the ORP menu as described above, but when asked whether you wish to perform a manual feed, press N/DOWN and the LCD will ask “SUPER CHLOR Y/N?”. Press Y/UP to enter the SUPER CHLOR sub-menu.

The LCD will then display “USE GOOD POOL DATA!”. This is a reminder to ensure that your D10 has been correctly set up for your particular pool. This should have been done at the time the D10 was installed and is done via the POOL sub-menu, accessed via the ADVANCED menu. This information “describes” your pool to the D10 – telling it the volume and also whether it is concrete or fibreglass.

After a few seconds, the LCD will read “ADD 5ppm of CHLOR”. You can increase the superchlorination dose to 10ppm by pressing the Y/UP button until the desired value is displayed. Press ENT to confirm your selection. The D10 will then use the data entered in the POOL menu to calculate how much chlorine is needed and proceed to add it. The LCD will then display the amount to be dosed. (Note: the dose volume displayed is an estimate only).

### Adjusting the Set Point

The ORP Set Point is the value in millivolts that the Chemigem will adjust your pool water to. You can adjust the ORP Set Point via the ORP Menu.

Enter the ORP Menu as described above, and press the N/DOWN button when asked whether you wish to do a manual feed and then again when asked if you wish to do a superchlorination. The LCD will then read “ADJUST SET POINT Y/N?” Press Y/UP to select this option and then the LCD will display the current set point. Adjust this using the Y/UP or N/DOWN buttons. Confirm the adjusted set point by pressing ENT. The new set point will then be displayed on the right hand side of line 3 of the LCD.

### **SWC (AUX) Settings** – for control of a Salt Water Chlorinator

The SWC (AUX) is off by default. To turn it ON simply press Y/UP. You will then be prompted to keep the chlorine dose pump ON too. If you only require the SWC unit to be enabled press N/DOWN to disable the automatic chlorine dosing pump – note that it is still available for manual dosing. Otherwise press Y/UP to allow automation of both systems.

There is a Delay value that can be adjusted from 0 to 60 minutes (default 30 minutes) – this delays the activation of the dose pump for a period after the unit starts.

When both systems are enabled the chlorine dosing is designed to only dose after the delay period and when the ORP has fallen far below the set point. This means that the chemical dosing will occur at times of high demand or very low residual.

### **Adjust ORP Control On or Off**

To disable the ORP System (or re-enable it if it has been disabled) you need to access the ORP menu and work your way through the MANUAL FEED, SUPER CHLOR and ADJUST SET POINT questions – pressing the N/DOWN button in response to each question.

The LCD will then read “ADJUST ORP CONTROL TURN OFF? Y/N” (if the system is ON) or ADJUST ORP CONTROL TURN ON? Y/N” (if the system is OFF). If you press Y/UP, the system will turn on (or off depending on its current status). If you answer N/DOWN to either question, the LCD will return to the home screen.

## **pH Menu**

### **Accessing the pH Menu**

Access the Chemigem Menu System by pressing ENT. Use the Y/UP or N/DOWN button to scroll through the main menu until pH MENU is displayed on the LCD. Press ENT to select.

### **Manual Feed**

Having accessed the pH menu, the LCD will ask “Manual Feed Y/N?”. Press Y/UP to select and the display (on solenoid valve models) will read “FEED 5 Sec/50mL”. On dosing pump models the display will read “FEED 5 mins/75mL”

You can increase the amount of the dose by pressing the Y/UP button until the desired dose amount is displayed. (Note: the dose volume displayed is an estimate only).

Press ENT and (depending on which model you have ) either the solenoid valve or the dose pump will commence feeding

## Adjusting the Set Point

The pH Set Point is the pH that the Chemigem will adjust your pool water to. You can adjust the pH Set Point via the pH Menu.

Enter the pH Menu as described above, and press the N/DOWN button when asked whether you wish to do a manual feed. The LCD will then read "ADJUST SET POINT Y/N?" Press Y/UP to select this option and then the LCD will display the current set point. Adjust this using the Y/UP or N/DOWN buttons. Confirm the adjusted set point by pressing ENT. The new set point will then be displayed on the right hand side of line 3 of the LCD.

## Calibration and Re-setting Factory Defaults

If your Chemigem consistently displays a pH reading different from that obtained by manual testing with a quality test kit, it may be necessary to re-calibrate the multi-electrode (probe). The instructions below assume the probe is measuring a pH of 7.8.

**Caution: do NOT re-calibrate the probe until identical pH readings have been obtained from at least three tests from around the pool. You will need to calibrate the probe to the pH value obtained from these test kit results.**

Enter the pH menu as described previously and press the N/DOWN button when asked whether you want to do a manual feed, and then again when asked whether you wish to adjust the set point.

The LCD will then read "CALIBRATE PROBE?". Press Y/UP to select this option and the LCD will read "PROBE Ph = 7.8 ADJUST TO +0.0". Use the Y/UP button to increase the adjusted value to the required level. Press ENT to confirm the adjustment and after a few seconds the Chemigem will revert to normal operation and the home screen will display the new pH value.

## Adjust pH System On or Off

To disable the pH System (or re-enable it if it has been disabled) you need to access the pH menu and work your way through the MANUAL FEED, ADJUST SET POINT and CALIBRATE PROBE questions – pressing the N/DOWN button in response to each question.

The LCD will then read "ADJUST pH CONTROL TURN OFF? Y/N" (if the system is ON) or "ADJUST pH CONTROL TURN ON? Y/N" (if the system is OFF). If you press Y/UP, the system will turn on (or off depending on its current status). If you answer N/DOWN to either question, the LCD will return to the home screen.

Note: Turning off the supply of acid is not normally necessary and could lead to unbalanced pool water that is unsafe to swim in. Pool Controls recommends that you seek advice from a qualified professional prior to disabling the pH system – or call Pool Controls Service on 1300 550 010.

# Chemigem Status Indicators, Warnings and Safety Features

## Normal Operation – Green Status Indicators

When the Chemigem is operating normally and ORP and pH readings are within the correct range, a green status indicator will be illuminated and the LCD will indicate the readings.

***Note: it is the pool owner's responsibility to monitor the pool and periodically confirm the Chemigem readings with a good quality test kit. Remember that the Chemigem is only able to balance pH and Chlorine levels – but you need to ensure other factors such as stabiliser levels and total alkalinity are within the correct range (see page 6 for details).***

## Low Chlorine

If the ORP falls significantly below the set point, this indicates that the chlorine levels in the pool have fallen and dangerous pathogens in the water are not being destroyed rapidly.

The Chemigem will warn of low chlorine with a red status indicator and the word “low” will be displayed on the ORP line (line 3) of the LCD.

Possible causes include:

- An empty chlorine drum
- Faulty solenoid valve or dose pump
- Low levels of stabiliser
- High pH
- Filter requires backwashing
- The multi-electrode (probe) may require cleaning (see page 24 for details)

If each of these factors is addressed, the Chemigem will dose the pool with chlorine until the set level is achieved – at which point the status indicator will revert to green and the warning will no longer be displayed on the LCD.

## High Chlorine

If the ORP rises significantly above the set point, a red status indicator will be illuminated and the word “High” will appear on the ORP line (line 3) of the LCD.

Possible causes include:

- Manual overdosing (superchlorination)
- Faulty solenoid valve or dose pump
- The multi-electrode (probe) may require cleaning (see page 24 for details)
- Low pH (too much pool acid)
- High Total Dissolved Solids (TDS)

There is no simple way to reduce high chlorine levels quickly. However, chlorine levels will eventually reduce over days (or weeks), particularly if the pool is exposed to sunlight.

### **Low pH – (Excess Acid)**

If the pH of the water drops below the set point, a red status indicator will be illuminated and the words “LOW pH” will be displayed on the LCD.

The Chemigem will automatically prevent any further acid being added to the pool until the pH is brought back into the correct range by the addition of sodium carbonate or sodium bicarbonate.

Possible causes include:

- Manual overdosing
- Excessive rainfall
- Faulty solenoid valve or dose pump
- The multi-electrode (probe) may require cleaning (see page 24 for details)
- Low Total Alkalinity
- Poor pool water circulation

### **Safety Shutdown**

If the pH falls below 5.8 the Chemigem will shut down pump operation to ensure no more acid gets into the pool.

### **High pH – (Insufficient Acid)**

If the pH rises significantly higher than the set point, a red status indicator will be illuminated and the words HIGH pH will be displayed on the LCD.

Note that a high pH can drastically reduce the ORP of the pool water, and therefore reduce the effectiveness of the sanitiser. It is important to restore the pH balance as soon as possible by adding acid to the pool.

Possible causes include:

- The acid drum is empty
- The pool has been superchlorinated recently
- The pool has a new plaster lining (very alkaline) demanding more acid than can be supplied by the Chemigem
- Faulty solenoid valve
- Filter requires backwashing
- Multi-electrode (probe) may require cleaning (see page 24 for details)
- Injector nozzle is blocked
- Venturi system (if fitted) is blocked

If each of these factors is addressed, the D10 will dose the pool with acid until the set level is achieved – at which point the status indicator will revert to green and the warning will no longer be shown on the LCD.

## Maintenance

Like all equipment the D10 will look better and last longer if it is maintained and operated in accordance with these instructions.

### The D10 Power Supply

The Power Supply has been design for operation in full sun and weather. However, it will benefit from being under cover. There is little maintenance required however – some Do's and Don'ts –

#### Don't:

- Install it in a small sealed enclosure (so it does not overheat)
- Install it in a very hot unventilated shed (so it does not overheat)
- Allow insects to nest in the unit (because they will prevent it from functioning)
- Install chemical drums under or close to the unit (to prevent corrosion)
- Forget about the unit once installed – it should be checked regularly to ensure that it is working for you

#### Do:

- Install it as per the instructions
- Check it regularly
- Make sure the pool balance is checked regularly

### Cleaning the Multi-electrode (Probe)

If the D10 is consistently giving readings different from those obtained from a test kit, it may be necessary to clean the multi-electrode.

To do this:

- Remove the probe from the injection point by twisting the bayonet (or if fitted with a tapping band, by unscrewing the retaining nut) and remove the o-ring.
- Holding the cable, gently swirl the probe in a dilute solution of hydrochloric acid (pool acid) for two minutes
- Rinse the probe in clean water and then replace it in the injection point, making sure that the "o-ring" is in place.
- Twist bayonet to lock (or tighten nut with fingers)

## Trouble-shooting

Before requesting service, you may wish to run through the check list below but feel free to call Pool Controls Service on 1300 550 010 or log a service call via our website – [www.poolcontrols.com.au](http://www.poolcontrols.com.au).

### If there appears to be low or no Chlorine Residual:

1. Check stabiliser level is 40ppm – 60ppm. Add if necessary and wait for it to dissolve.
2. Have you added any chemical additives recently?
3. Check pool for phosphates and remove if necessary
4. Is the unit turned on and operating the filter pump?
5. If the unit is not running at all, check the fuse in the bottom of the unit.

