

# Powerline Control

## User Manual for PL Series pH /ORP Controller





# Contents

Warranty Terms	2
Basic Maintenance by Pool Owner	4
How it Works	5
Initial Pool Balance	6
Installation Guide & Diagram	7
Front Panel and Power Outage Operation	10
Operation Buttons Description	11
Troubleshooting	12
Navigating the Menu System	12
Timer Menu	13
ORP Menu	15
pH Menu	16
Status Indicator, Warnings and Safety Shutdowns	18
Maintenance	20

## IMPORTANT

*If the power cord is damaged the unit must be returned to Hayward for repair.*

*Always read the instructions and warnings on chemical containers before using chemicals.*

Serial Number.....

Date of Installation.....

Installed by.....

## Standard Warranty – Professional Sales and Installation – Effective July 1st, 2016

To the original purchaser only, on-site warranty is provided at the discretion of Hayward Pool Products (Australia) Pty Ltd and is available according to the following schedule and is subject to our standard warranty conditions.

Product Description	Sold and installed by an approved installer	
	Parts	In-field Labour
Powerline Control Box, Dosing System & Electrolytic Cell*2	3 Years	1 Year
Spare Parts*3	1 Year	1 Year

**Eligibility to claim**

To be eligible to claim warranty support available to the original purchaser, prior to repairs being undertaken you must:

- Provide proof of purchase and installation by an Authorised/ Qualified Professional Dealer.
- Where warranty claim is made, supply and installation must be completed by an Authorised/ Qualified Professional Dealer or Builder, warranty certificate must be completed including installer's full business details, copy of original receipt and signature of approved partner's representative. Where proof of professional installation is not provided, warranty is limited to 12 months- parts only.
- Where proof of purchase cannot be provided you will not be entitled to warranty support.
- Any item that is hard wired to a power supply cannot be serviced on site. In this case contact Hayward Pool Products (Australia), an Authorised Service Agent or place of purchase for instruction.

**Conditions**

- On-site support will only be provided for installations located within 10km of the Authorised Service Agent in the metropolitan areas of Melbourne, Sydney, Brisbane and Perth, or within 20km of an Authorised Service Agent in regional areas. For Installations outside the specified radius the customer may have to pay a travel fee. Warranty does not cover damages resulting from incorrect installations, improper storage, improper operation, water chemistry or freezing.
- To claim warranty a history of water balance test records must be provided to show compliant water balance has been maintained for the product.
- Parts including mechanical seals, multiport valves, elements, pressure gauges, grids, cartridges, bearings, shoes, wings and drive tracks are considered spare parts and therefore qualify for 1 year manufacturer's defect warranty. Warranty commences from date of original purchase and is not extended in the event of a repair or replacement. Squeeze tubes on peristaltic pumps need to be replaced every 6 months

### Warranty- Standard Conditions

Hayward Pool Products (Australia) Pty Ltd (ACN 083 413 414) ("Hayward Pool Products (Australia)") distributes Hayward Pool Products in Australia and New Zealand and provides the following warranties:

### STATUTORY RIGHTS

- The benefits to the consumer under this warranty are in addition to other rights and remedies of the consumer under the laws in relation to the goods and services to which the warranty relates; and
- Our goods come with guarantees that cannot be excluded under the Australian Consumer Law. You are entitled to a replacement or refund for a major failure and compensation for any other reasonably foreseeable loss or damage. You are also entitled to have the goods repaired or replaced if the goods fail to be of acceptable quality and the failure does not amount to a major failure.

### LIMITED WARRANTY

Hayward Pool Products (Australia) warrants that its products are free from defects in materials and manufacture for 12 months from date of supply by Hayward Pool Products (Australia) plus 90 days to allow for installation and supply (unless otherwise specified). Hayward Pool Products (Australia) will at its discretion, except in the circumstances described below, either replace or repair any product proven to be defective during the warranty period for either materials or manufacture or alternatively pay the cost of repair or replacement within 90 days of the receipt of the defective product, barring unforeseen delays. This warranty is personal to the original purchaser and does not pass to any subsequent purchaser(s).

To the extent permitted by law, Hayward Pool Products (Australia) will not be liable for products which fail or become defective during the warranty period as a result of freezing, accident, negligence, improper installation, water chemistry, misuse or lack of care.

To the extent permitted by law, except as set out in this Warranty, Hayward Pool Products (Australia) excludes all statutory or implied conditions and warranties and any other liability it may have to the Customer (including liability for indirect or consequential loss) that may arise under statute or at law including without limitation for breach of contract, in tort (including negligence) or under any other cause of action.

To the extent permitted by law, except as set out in this Warranty, Hayward Pool Products (Australia) limits its liability under any condition or warranty which cannot be legally excluded in relation to the supply of Goods and Services to:

1. Replacing the Goods or supplying equivalent Goods or Services again;
2. Repairing the Goods;
3. Paying the cost of replacing the Goods or of supplying equivalent Goods or Services again; or
4. Paying the costs of repairing the Goods.

## PRODUCTS REQUIRING QUALIFIED INSTALLATION

Some products due to their technical nature are only intended for sale by retail shops where local sales and technical support can be provided or as a part of a new Pool Installation. Where installation has not been carried out in accordance with this requirement, warranty labour and support will be the sole responsibility of the reseller supplying the product. Warranty claims for such products will be limited to replacement of parts only, with faulty goods being returned to place of purchase for processing.

The following products as well as those that may be designated by Hayward Pool Products (Australia) from time to time, are not specifically intended for owner installation and are deemed to be technical products:-

- Heaters - All;
- Hayward Dosing and Chemistry Control;
- Hayward Pool and Spa Controls;
- Puresilk and Powerline Dosing and Chemistry Control;

Claims made for warranty, labour or infield support will not be accepted by Hayward Pool Products unless evidence is provided that installation has been completed in accordance with standard warranty conditions. Please refer to specific program document for details.

## HEATING PRODUCTS

Please note that warranty claims for Heaters are handled directly by Hayward Pool Products (Australia) and are not authorised for over the counter exchanges. These items are site specific and involve local conditions such as placement, installation, water chemistry, fuel supply and electricity. Each unit needs to be evaluated on the site utilising Hayward Pool Products (Australia)'s authorised service network. Hayward Pool Products (Australia) will not be responsible for additional costs incurred where a heater has been installed at a location situated further than 20km from an authorised service outlet. Advice must be sought in writing from Hayward Pool Products (Australia) to determine appropriate service procedure on a case by case basis.

## EXCLUSION FOR WEARING PARTS

This warranty does not extend to wearing parts, in particular the squeeze tubes fitted in peristaltic dosing pumps. Squeeze tubes should be replaced every six months by a suitably qualified technician. Hayward is not liable for any failure of its products or other damage caused by failure of a squeeze tube that has been used for more than six months.

### **Hayward Pool Products (Australia) Pty Ltd**

ABN 66 083 413 414

PO Box 4384, Dandenong South, VIC, 3164

Melbourne, Sydney, Brisbane, Perth

T (+61) 3 9792 2325 or 1300 POOLS1

F (+61) 3 9794 9945 or 1300 POOLS2

email: [sales@hayward-pool.com.au](mailto:sales@hayward-pool.com.au) web: [www.hayward-pool.com.au](http://www.hayward-pool.com.au)

## What's in the box?

- Multi-electrode (probe)
- PL Control Power Supply
- Tubing for acid feed
- Peristaltic pump module
- User Manual
- Injection manifold
- Mounting hardware (raw plugs, screws and paper template)

## IMPORTANT SAFETY MEASURES:

- Always add concentrated chemicals to water – not the other way around!
- Don't allow chemicals to mix – **dangerous, highly corrosive fumes produced.**
- Always wear protective clothing, footwear, gloves and eye protection when handling pool chemicals to avoid injury.
- If a spill occurs, wash the affected area with fresh water immediately and seek medical attention.
- **Work in a well-ventilated area and avoid inhalation of fumes.**
- Read and follow safety instructions on chemical drums.

# Basic Maintenance by Pool Owner

Your PL Control maintains pool water biological safety by controlling the pH and the ORP (sanitation level). It achieves this by dosing the necessary chemicals into the pool in a controlled manner. The chemical drums must be checked on a regular basis – empty drums will lead to poor balance and incorrect operation.

To achieve water safety effectively and efficiently there are other water balance factors that must be maintained by the pool owner.

The most important water balance factors are described on page 6.

Failure to maintain these aspects of pool water balance can lead to poor water quality and incorrect/unusual operation of the PL Control unit.

In the case of incorrect or unusual operation the pool water must be tested and any balance problems corrected. After this is done it may also be necessary to clean the Probe – this is part of the unit maintenance, see page 21.

## How it works:

The PL Control continuously analyses pool water chemistry while your pool system is running. The base model has two dosing pumps that dose liquid chlorine and acid to the pool water flow in response to the water analysis from the probe.

The PL Control can also be used to control a Salt Water Chlorinator, with or without extra liquid chlorine dosing.

**Note: the filter system should always be running when the pool is being used.**

### Oxidation Reduction Potential

The PL Control measures how much chlorine is in pool water by measuring the ORP of the water.

ORP stands for Oxidation Reduction Potential. Chemicals like chlorine destroy pathogens (eg harmful bacteria) in water by oxidising them.

The level of oxidation available in the water can be measured chemically with an ORP sensor contained in the PL Control's multielectrode (probe). This produces a voltage related to the ORP of the water, which is a measure of the effectiveness of chlorine in the water.

Varying the ORP will affect how long it takes to destroy harmful bacteria in pool water. For example, if ORP is maintained at 650mV, E-coli type bacteria will be destroyed in around one second. However, if the ORP is lowered to 550mV, the same organisms may take up to 2 hours to be eliminated.

### pH Control

When chlorine is added to water the pH always changes – this is because chlorine is not a neutral chemical. The pH will slowly rise as chlorine is added to the water. A rise in pH greatly reduces the effectiveness of the chlorine as a sanitiser, so it is important to ensure that the pH remains in the correct range.

The pH of the water can be lowered by the addition of acid – and your PL Control does this automatically. The PL Control multielectrode (probe) measures the pH of the water and doses the pool with small amounts of acid to keep the pH in the correct range.

## Initial pool balance

Before you begin using the PL Control make sure your pool water is balanced as follows:

### Chlorine

If it is a new installation, add enough chlorine (liquid or granular) to achieve a reading of 3ppm on an appropriate test kit.

### Stabiliser

If the pool is outdoors, it is vital that stabiliser (also known as cyanurate and cyanuric acid) be added and maintained at 40ppm to 60ppm. This compound reduces chlorine destruction due to sunlight. However, too much stabiliser will reduce the effectiveness of chlorine and can result in poor quality water so ensure stabiliser does not exceed 80ppm.

***Good stabiliser level keeps good chlorine levels and reduces maintenance.***

### pH

For chlorine to be effective, the pH must be within a certain range. This is usually between 6.8 (fibreglass/liner pools) or 7.2 (concrete/plaster) and 7.8.

Adjust pH down with acid – powder, liquid sulphuric or liquid hydrochloric. Be very careful with acid as it can be harmful and corrosive.

### Total Alkalinity (TA)

Total alkalinity is also known as carbonate hardness or TA for short. The recommended level is between 80 and 120ppm.

TA is related to pH in that it stops the pH from varying quickly with small additions of acidic or alkaline chemicals. When the TA is low it is almost impossible to control the pH.

To raise the TA, buffer (sodium bicarbonate) is added. This must be done slowly as buffer will also cause the pH to rise. As an approximate rule every increase of 20ppm of TA will also cause a 0.1 rise in pH. Once buffer is added it should be left to mix in the pool for a few hours before reducing the pH.

### Phosphates and Nitrates

Phosphate and ammonia nitrogen will make your garden green – and they will do the same thing to your pool. Check for phosphates and add phosphate remover if necessary. Don't let fertiliser get into your pool! Ammonia nitrogen has a very high chlorine demand.

Phosphates are also in some cleaning products – check the label if using around your pool.

### When Controlling a Salt Water Chlorinator (SWC)

Follow the directions for the initial balance for your SWC unit – the difference is likely to only be the addition of salt or minerals. Note that the PL Control unit will turn the power to the SWC unit on and off – the SWC unit must be capable of functioning in this manner and should be set to manual operation only (not automatic).

***Special Note:*** SWC units produce compounds other than chlorine. If complex chemicals are added to the pool there is a greater likelihood that the readings for ORP will be affected by these electrolysis products. Pool additives containing phosphonates, organic acids and their salts, polymers and polymer acids should be avoided.



# Installation Guide

## Choosing a good location

The PL Control is manufactured from weather resistant materials and is designed for operation in full sun and rain. However, your PL Control will benefit if it is protected from the weather. The PL Control Power Supply should not be mounted close to where chemicals are stored (eg acid and chlorine) as vapours from these chemicals are corrosive and may damage the electronic controls within the unit.

Insect intrusion (particularly ants) can cause problems with all equipment. Ensure that the pool equipment area is kept free of insects as much as possible. Insect intrusion is not covered under the warranty.

## Installing the PL Control Controller

Locate the PL Control Power Supply close to the filtration pump so that it may be connected easily. Connect the PL Control Power Supply to the mains power outlet of the pool area and make sure this outlet meets all applicable Australian Standard at the time of installation.

Mount the PL Control Power Supply at least 1.5m above the ground and at least 3m from the pool water. A mounting template is printed on the last page of the manual.

The PUMP socket outlet in the base of the PL Control Power Supply is dedicated to the filtration pump only. Do not use a double adaptor to connect another pump as this will overload the system and void warranty.

Your PL Control has two other power outlets on its base, which can be used to run lighting or an SWC unit (or other pool equipment). These outlets are also timed, so accessories can be set to turn on and off automatically.

## Installing the Injection Manifold

The injection manifold should be installed on the return (pressure) side of the pump, after accessories such as heater, but before the chlorinator cell if fitted. Ensure that the water flow is in the correct direction (as marked on the injection manifold).

## Installing the Probe into the Injection Manifold

The probe has a bayonet fitting. To install the probe, simply insert it into the injection manifold and twist to lock the bayonet fitting. Ensure that the o-ring seal is not twisted or out of place.

## Chemical drums

Position the chemical drums in a safe and secure location, preferably about 2 metres from the PL Control . Ensure you have the right chemicals for your pool and that chemicals have been diluted if necessary.

### Installing the Peristaltic Pump (for Chlorine and/or Acid Feed)

Mount the peristaltic pump unit adjacent to the PL Control Unit, as it is hard-wired to this power supply.

The injection point is supplied with a short length of tube terminating in a Y-piece. The outlet of each dosing pump is to be connected to each arm of the Y-piece. The pumps are marked for Acid or Chlorine. **Do not place the Y-piece directly under the pump module – this will reduce the life of the pump squeeze tubes. Each pump outlet should have a long run of tube with a gas-trap loop close to the Y-piece near the injection point.**

Cut a length of tubing that will reach from the base of the peristaltic pump to the injection manifold **including enough for a loop to act as a gas-trap**. Connect one end of the tubing to the outlet side of the peristaltic pump (the direction of flow is indicated by an arrow on the front cover of the pump.) Connect the other end of the tube with loop to the Y-piece near the injection point on the injection manifold.

Cut another length of tubing that will reach from the base of the peristaltic pump to the base of the chemical drum. Position the chemical drum in a safe and secure location, preferably about 2 metres from the PL Control unit.

Connect the end of this tube to the inlet side of the peristaltic pump - the direction of flow is indicated by an arrow on the front cover of the peristaltic pump.

Drill an 8mm hole in the lid of the chemical drum and pass the tubing through the hole in the drum lid. Place a sinker on to the end of the tubing that will be in the chemical drum and then attach the drum filter. Note that the drum filter incorporates a non-return valve to prevent back-flow into the chemical drum.

Before placing the tubing into the drum, measure the tubing against the outside of each drum and wrap several turns of PVC tape around the tubing above the drum lid so that the drum filter will be 10-15mm above the bottom of the drum. Lower the drum filter and sinker into the drum and screw on the lid.

# INSTALLATION DIAGRAM

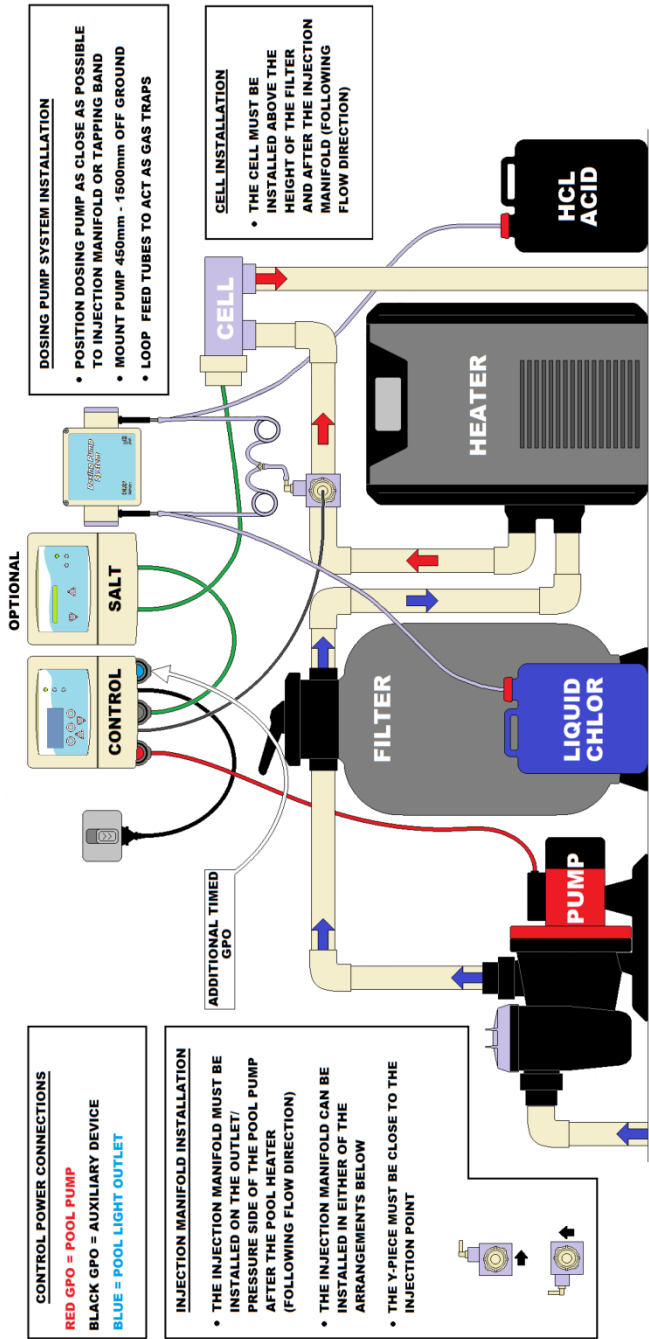

## The PL Control Front Panel

### PL Control Display

The PL Control uses a four line LCD display to provide the user with information.

**LCD Display**

<b>Line 1</b>	<b>15:27</b>	<b>NORMAL Auto</b>
<b>Line 2</b>	<b>AutoON → AutoOFF@ 21:00</b>	
<b>Line 3</b>	<b>ORP=670mV</b>	<b>SET=650mV</b>
<b>Line 4</b>	<b>pH= 7.5</b>	<b>SET= 7.6</b>

READ OPERATION MANUAL FOR DETAILED INSTRUCTIONS

- Line 1 shows the current time and the mode of operation.  
In the example above, line 1, tells you that the time is 3:27pm and the PL Control is operating in “Normal Automatic mode”  
Note that the PL Control displays the time using a 24 hour clock.
- Line 2 shows timer information.  
In the example above, line 2 tells you that the “unit is turned ON and will turn OFF automatically at 21:00 (9pm)”
- Line 3 displays ORP (Chlorine) information.  
In the example above, line 3 tells you that the current ORP is 670mV with the unit set to provide 650mV
- Line 4 displays pH information.  
In the example above, line 4 tells you that the current pH is 7.5 with the unit set to provide 7.6.

### Operation Following a Power Failure

The PL Control unit comes with a timer function built into the operating software. The timer is a 24-hour type with quartz-crystal control . This Timer is backed-up by a Real-Time Clock (RTC) similar to those found in computers.

During a power failure the PL Control will keep time and maintain AutoMode functions.

If a Filter Cycle is active when power is returned the pump will be turned ON within 1 minute. The PL Control will keep all its settings and will not need to be re-programmed.

The PL Control is ideal for use in systems where repeated power cuts occur, such as off-peak power circuits and Queensland’s Tarriff33 system.

## PL Control Operational Buttons

Your PL Control has 5 buttons that allow you to Control the various functions available via the PL Control Menu system.

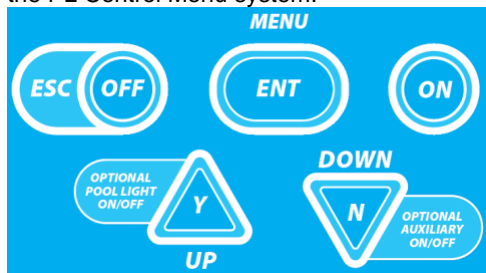

Each button is labelled with its primary function either on the button itself, or adjacent to it. Secondary functions are labelled within a curved white outline next to the relevant button. The buttons are backlit to show which are active at any given time, although the ESC/OFF button is always available to take you back to the home screen.

### ON Button

#### Turn the System On Manually

Press the ON button once to switch the PL Control and the pool pump on manually. The PL Control will default back to AUTO and turn itself off automatically at the end of the next programmed FILTER CYCLE (and this time will be displayed on the LCD).

#### Increasing Manual Run-time in Hourly Increments

Press the ON button repeatedly (or hold the button down) to increase the manual run time in hourly increments. The run time is displayed on the LCD. When the desired run time has been reached, press the ENT button to confirm your selection and the system will commence operation.

### ESC/OFF Button

#### Turn the System Off Manually

If the PL Control and pool pump are running, pressing this button will turn them off manually. The PL Control will automatically turn on again at the start of the next FILTER CYCLE (and this will be displayed on the LCD).

#### Return to Home Screen

If you have unintentionally accessed a PL Control Menu that you don't actually require, pressing the ESC/OFF button allows you to return to the home screen at any time.

## ENT Button

Use this button to enter the PL Control Menu system and to access the various options in each Menu. Use the Y/UP and N/DOWN buttons to scroll through menu options and when your desired menu option is displayed on the LCD, press ENT to access that option.

## Y/UP Button and Optional Pool Light

If you have accessed the PL Control Menu by pressing the ENT button, press the Y/UP button to scroll upwards through the various menu options. Some menu options will prompt a yes or no answer. If you wish to answer “yes”, press the Y/UP button.

If your PL Control also controls your pool lighting (optional), you can turn the lights on or off manually by pressing the Y/UP button. For multi-coloured lights, hold the Y/UP button down to cycle through the various colours and release once the desired colour is reached.

## Navigating the PL Control Menu System

There are three aspects to the general PL Control Menu system – the Timer Menu, the ORP (Chlorine) Menu and the pH Menu.

Access the PL Control Menu system by pressing the ENT button and following the prompts on the LCD. If you find you have ended up in a part of the Menu system unintentionally, you can return to the Home Screen by pressing the ESC/OFF button at any time.

Use the Y/UP and N/DOWN buttons to scroll through the various menu options until the desired option is displayed on the LCD. Use the ENT button to confirm that you wish to select that option.

Once accessed, use the Y/UP and N/DOWN buttons to adjust operational settings up or down – and confirm adjustments by pressing ENT. To cancel any adjustments, simply press ESC/OFF to return to the Home Screen.

## Trouble-shooting

Before requesting service, you may wish to run through the check list below but feel free to call Hayward Service on 1300 POOLS1 or log a service call via our website – [www.hayward-pool.com.au](http://www.hayward-pool.com.au).

### If there appears to be low or no Chlorine Residual:

1. Check stabiliser level is 40ppm – 60ppm. Add if necessary and wait for it to dissolve.
2. Have you added any chemical additives recently?
3. Check pool for phosphates and remove if necessary
4. Is the unit turned on and operating the filter pump?
5. If the unit is not running at all, check the fuse in the bottom of the unit.

**DANGER: ENSURE TO REMOVE THE UNIT'S POWER CORD FROM THE POWERPOINT (GPO) BEFORE REMOVING THE FUSE**

## Timer Menu

### Setting the time

Once you have installed your PL Control and turned it on, you will need to set the correct time on the PL Control 's 24 hour clock.

First, access the Menu System by pressing the ENT button.

The LCD will display the word TIMER MENU. Select this by pressing the ENT button once more.

Line 2 on the LCD will now read SET TIME HOURS. Press ENT to select this option and then use the Y/UP and N/DOWN buttons- to adjust the hours on the LCD. Confirm the correct hours value by pressing ENT again.

The LCD will now show SET TIME MINUTES. Adjust the minutes using the Y/UP and N/DOWN buttons. When complete, press ENT to return to normal operation.

## ADJUST CYCLES Sub-Menu

Your PL Control has two filter cycles pre-programmed as factory defaults as follows:

Filter Cycle 1:	ON at 7:00 (7am)	OFF at 10:00 (10am)
Filter Cycle 2:	ON at 18:00 (6pm)	OFF at 21:00 (9pm)

You can change the start and finish times of each filter cycle to meet your sanitiser requirements and to suit your lifestyle.

To adjust filter cycle start and finish times, press ENT to access the PL Control Menu system. Press ENT again to select the TIMER menu and then scroll down using the N/DOWN button until ADJUST CYCLES is displayed on the LCD.

Select this option by pressing ENT and the LCD will show the start (ON) time of the filter cycle being adjusted. Use the Y/UP and N/DOWN buttons to adjust the start time. Press ENT to confirm your selection and then the LCD will show the end (OFF) time for that filter cycle. Adjust the OFF time in the same way as the ON time and press ENT to confirm.

After ON and OFF times for the first filter cycle have been adjusted, the ON time for the second filter cycle is shown on the LCD. This can be adjusted in the same way, or if you do not wish to make any changes, simply press ENT to confirm the time shown on the LCD. Follow the same process to either adjust or confirm the OFF time for the second filter cycle, and once this has been confirmed the LCD will display the home screen.

Note: an additional 2 filter cycles can be enabled and programmed via the Advanced Settings Menu. For details on how to access this menu, please refer to the Advanced Settings Manual (available to download from [www.hayward-pool.com.au](http://www.hayward-pool.com.au)) or call Hayward Service on 1300 POOLS1.

## Running Times

We recommend your system be operated for ***at least 4 hours per day and always run the system when using the pool.***

As sunlight destroys chlorine, it is recommended that the PL Control be run mostly in the evening.

Chlorine is added for sanitation but the filter is needed to remove pollutant particles (dust, sand etc) and keep the water looking good. The filter must operate for a reasonable number of hours per day to remove pollutants. If there are adverse local conditions – such as windborne dust and debris - the chlorine demand will be higher than normal and you will likely need to operate the system for longer periods to adequately filter the water.

## LIGHT Timer Sub-Menu

You can use your PL Control to turn your pool or garden lighting on and off automatically, you can set the ON and OFF times using the light timer menu.

Press ENT to access the PL Control Menu system. Press ENT again to select the TIMER menu and then scroll down using the N/DOWN button until LIGHT MENU is displayed on the LCD.

Line 2 on the LCD will now read “AUTO? Y/N”. To enable automatic light operation press the Y/UP-button. Line2 will read “Auto ON” for short period before displaying “ON hh:mm”.

Adjust the ON time using the Y/UP and N/DOWN-buttons and confirm by pressing ENT. The LCD will now prompt you to set the OFF-time, which is accomplished using the Y/UP and N/DOWN-buttons as before. Press ENT-to confirm the new OFF-time and the LCD will return to the home screen.

To disable automatic light operation, access the LIGHT menu in the way described above and when asked “AUTO? Y/N” - press the N/DOWN button. Line 2 will read “Auto OFF” for short period then the system will return to normal operation and the light can only be operated manually (see below for how to do this).

## Manual Light Operation

If the PL Control is turned on, the light can be turned on or off manually by pressing the Y/UP-button.

If you have multi-coloured LED lights that cycle through different colours and requiring a power pulse to change effects, you can hold down the Y/UP-button to cycle through the options and release when the desired colour or effect is achieved.



# ORP (Chlorine Menu)

## Accessing the ORP Menu

Access the PL Control Menu System by pressing ENT. Use the Y/UP or N/DOWN button to scroll through the main menu until ORP MENU is displayed on the LCD. Press ENT to select.

## Manual Feed

Having accessed the ORP menu, the LCD will ask “Manual Feed Y/N?”. Press Y/UP to select and the display will read “FEED 5 mins/75mL”

You can increase the amount of the dose by pressing the Y/UP button until the desired dose amount is displayed. (Note: the dose volume displayed is an estimate only)

Press ENT and the peristaltic pump will commence feeding liquid chlorine.

## Adjusting the Set Point

The ORP Set Point is the value in millivolts that the PL Control will adjust your pool water to. You can adjust the ORP Set Point via the ORP Menu.

Enter the ORP Menu as described above, and press the N/DOWN button when asked whether you wish to do a manual feed. The LCD will then read “ADJUST SET POINT Y/N?” Press Y/UP to select this option and then the LCD will display the current set point. Adjust this using the Y/UP or N/DOWN buttons. Confirm the adjusted set point by pressing ENT. The new set point will then be displayed on the right hand side of line 3 of the LCD.

## Adjust ORP Control On or Off

To disable the ORP System (or re-enable it if it has been disabled) you need to access the ORP menu and work your way through the MANUAL FEED and ADJUST SET POINT questions – pressing the N/DOWN button in response to each question.

The LCD will then read “ADJUST ORP Control TURN OFF? Y/N” (if the system is ON) or ADJUST ORP Control TURN ON? Y/N” (if the system is OFF). If you press Y/UP, the system will turn on (or off depending on its current status). If you answer N/DOWN to either question, the LCD will return to the home screen.

## pH Menu

### Accessing the pH Menu

Access the PL Control Menu System by pressing ENT. Use the Y/UP or N/DOWN button to scroll through the main menu until pH MENU is displayed on the LCD. Press ENT to select.

### Manual Feed

Having accessed the pH menu, the LCD will ask “Manual Feed Y/N?”. Press Y/UP to select and the display will read “FEED 5 mins/75mL”

You can increase the amount of the dose by pressing the Y/UP button until the desired dose amount is displayed. (Note: the dose volume displayed is an estimate only).

Press ENT and the peristaltic pump will commence feeding

### Adjusting the Set Point

The pH Set Point is the pH that the PL Control will adjust your pool water to. You can adjust the pH Set Point via the pH Menu.

Enter the pH Menu as described above, and press the N/DOWN button when asked whether you wish to do a manual feed. The LCD will then read “ADJUST SET POINT Y/N?” Press Y/UP to select this option and then the LCD will display the current set point. Adjust this using the Y/UP or N/DOWN buttons. Confirm the adjusted set point by pressing ENT. The new set point will then be displayed on the right hand side of line 3 of the LCD.

### Calibration and Re-setting Factory Defaults

If your PL Control consistently displays a pH reading different from that obtained by manual testing with a quality test kit, it may be necessary to re-calibrate the multi-electrode (probe). The instructions below assume the probe is measuring a pH of 7.8.

**Caution: do NOT re-calibrate the probe until identical pH readings have been obtained from at least three tests from around the pool. You will need to calibrate the probe to the pH value obtained from these test kit results.**

Enter the pH menu as described previously and press the N/DOWN button when asked whether you want to do a manual feed, and then again when asked whether you wish to adjust the set point.

The LCD will then read “CALIBRATE PROBE?”. Press Y/UP to select this option and the LCD will read “PROBE pH = 7.8 ADJUST TO +0.0”. Use the Y/UP button to increase the adjusted value to the required level. Press ENT to confirm the adjustment and after a few seconds the PL Control will revert to normal operation and the home screen will display the new pH value.

## **Adjust pH System On or Off**

To disable the pH System (or re-enable it if it has been disabled) you need to access the pH menu and work your way through the MANUAL FEED, ADJUST SET POINT and CALIBRATE PROBE questions – pressing the N/DOWN button in response to each question.

The LCD will then read “ADJUST pH Control TURN OFF? Y/N” (if the system is ON) or ADJUST pH Control TURN ON? Y/N” (if the system is OFF). If you press Y/UP, the system will turn on (or off depending on its current status). If you answer N/DOWN to either question, the LCD will return to the home screen.

Note: Turning off the supply of acid is not normally necessary and could lead to unbalanced pool water that is unsafe to swim in. Hayward recommends that you seek advice from a qualified professional prior to disabling the pH system – or call Hayward Service on 1300 POOLS1.

# PL Control Status Indicators, Warnings and Safety Features

## Normal Operation – Green Status Indicators

When the PL Control is operating normally and ORP and pH readings are within the correct range, a green status indicator will be illuminated and the LCD will indicate the readings.

***Note: it is the pool owner's responsibility to monitor the pool and periodically confirm the PL Control's readings with a good quality test kit. Remember that the PL Control is only able to balance pH and Chlorine levels – but you need to ensure other factors such as stabiliser levels and total alkalinity are within the correct range (see page 6 for details).***

### Low Chlorine

If the ORP falls significantly below the set point, this indicates that the chlorine levels in the pool have fallen and dangerous pathogens in the water are not being destroyed rapidly.

The PL Control will warn of low chlorine with a red status indicator and the word “low” will be displayed on the ORP line (line 3) of the LCD.

Possible causes include:

- An empty chlorine drum
- Faulty peristaltic pump
- Low levels of stabiliser
- High pH
- Filter requires backwashing
- The multi-electrode (probe) may require cleaning (see page 20 for details)

If each of these factors is addressed, the PL Control will dose the pool with chlorine until the set level is achieved – at which point the status indicator will revert to green and the warning will no longer be displayed on the LCD.

### High Chlorine

If the ORP rises significantly above the set point, a red status indicator will be illuminated and the word “High” will appear on the ORP line (line 3) of the LCD.

Possible causes include:

- Manual overdosing (superchlorination)
- Faulty peristaltic pump
- The multi-electrode (probe) may require cleaning (see page 24 for details)
- Low pH (too much pool acid)
- High Total Dissolved Solids (TDS)

There is no simple way to reduce high chlorine levels quickly. However, chlorine levels will eventually reduce over days (or weeks), particularly if the pool is exposed to sunlight.

## **Low pH – (Excess Acid)**

If the pH of the water drops below the set point, a red status indicator will be illuminated and the words “LOW pH” will be displayed on the LCD.

The PL Control will automatically prevent any further acid being added to the pool until the pH is brought back into the correct range by the addition of sodium carbonate or sodium bicarbonate.

Possible causes include:

- Manual overdosing
- Excessive rainfall
- Faulty peristaltic pump
- The multi-electrode (probe) may require cleaning (see page 24 for details)
- Low Total Alkalinity
- Poor pool water circulation

## **Safety Shutdown**

If the pH falls below 5.8 the PL Control will shut down pump operation to ensure no more acid gets into the pool.

## **High pH – (Insufficient Acid)**

If the pH rises significantly higher than the set point, a red status indicator will be illuminated and the words HIGH pH will be displayed on the LCD.

Note that a high pH can drastically reduce the ORP of the pool water, and therefore reduce the effectiveness of the sanitiser. It is important to restore the pH balance as soon as possible by adding acid to the pool.

Possible causes include:

- The acid drum is empty
- The pool has been superchlorinated recently
- The pool has a new plaster lining (very alkaline) demanding more acid than can be supplied by the PL Control
- Faulty squeeze tube
- Filter requires backwashing
- Multi-electrode (probe) may require cleaning (see page 24 for details)
- Injector nozzle is blocked

If each of these factors is addressed, the PL Control will dose the pool with acid until the set level is achieved – at which point the status indicator will revert to green and the warning will no longer be shown on the LCD.

## Maintenance

Like all equipment the PL Control will look better and last longer if it is maintained and operated in accordance with these instructions.

### The PL Control Power Supply

The Power Supply has been design for operation in full sun and weather. However, it will benefit from being under cover. There is little maintenance required however – some Do's and Don'ts –

#### Don't:

- Install it in a small sealed enclosure (so it does not overheat)
- Install it in a very hot unventilated shed (so it does not overheat)
- Allow insects to nest in the unit (because they will prevent it from functioning)
- Install chemical drums under or close to the unit (to prevent corrosion)
- Forget about the unit once installed – it should be checked regularly to ensure that it is working for you

#### Do:

- Install it as per the instructions
- Check it regularly
- Make sure the pool balance is checked regularly

### Cleaning the Multi-electrode (Probe)

If the PL Control is consistently giving readings different from those obtained from a test kit, it may be necessary to clean the multi-electrode.

To do this:

- Remove the probe from the injection point by twisting the bayonet (or if fitted with a tapping band, by unscrewing the retaining nut) and remove the o-ring.
- Holding the cable, gently swirl the probe in a dilute solution of hydrochloric acid (pool acid) for two minutes
- Rinse the probe in clean water and then replace it in the injection point, making sure that the “o-ring” is in place.
- Twist bayonet to lock (or tighten nut with fingers)



